



SAMSUNG 65XXII (V2.00)

PROGRAM MANUAL

NOTE

**IT SHOULD BE NOTED THAT BOTH THE MANUAL AND FIRMWARE
ARE SUBJECT TO CHANGE WITHOUT NOTIFICATION**

INTRODUCTION

INSTALLATIONS..... 8
RIBBON CASSETTE INSTALLATION 8
RECEIPT/JOURNAL PAPER INSERTION 8
ALL CLEAR PROCEDURE..... 9
INITIAL CLEAR PROCEDURE10
INSTALL DEFAULT KEYBOARD10

S-MODE

S-MODE SERVICE FUNCTIONS11
S-POSITION SERVICE FUNCTIONS.....12
REGISTER NUMBER PROGRAMMING12
SETTING LEVEL STAY DOWN.....12
COMMUNICATIONS SETTINGS13
S-POSITION COMMUNICATION TEST.....13
FUNCTION KEYS.....14
S-MODE KEY RELOCATION PROGRAMMING14
KEY DESCRIPTION15
S-MODE SYSTEM OPTIONS.....19

P-MODE

ALPHANUMERIC CHARACTERS.....23
USING DIRECT CHARACTER KEY ON KEYBOARD.23
USING CHARACTER CODE23
CHARACTER CODES.....24
SER 6500/40 CHARACTER CODE TABLE24
CHARACTER MAP.....25
SER 6540 KEY CHARACTER MAP25
PROGRAM ACCESS CODES LIST26
PROGRAMMING SCANS27

P-POSITION PROGRAMMING SCANS	27
P-MODE SYSTEM OPTIONS	28
OPTION PROGRAMMING	28
P-MODE SYSTEM OPTIONS - 40	29
P-MODE PRINTING OPTIONS - 50	31
P-MODE COMMUNICATIONS OPTIONS - 60	35
TAX PROGRAMMING.....	41
TABLE TAX RATE PROGRAMMING.....	42
CASH KEY PROGRAMMING	44
CHEQUE KEY PROGRAMMING.....	45
CHARGE KEY PROGRAMMING.....	46
CURRENCY KEY PROGRAMMING.....	47
% KEY PROGRAMMING.....	48
ERR CORR KEY PROGRAMMING	50
VOID KEY PROGRAMMING	51
PROMO KEY PROGRAMMING.....	52
WASTE KEY PROGRAMMING	53
CANCEL KEY PROGRAMMING	54
PAID OUT KEY PROGRAMMING.....	55
RECEIVED ON ACCOUNT KEY PROGRAMMING.....	56
RETURN KEY PROGRAMMING	57
TAX EXEMPT KEY PROGRAMMING	58
EAT-IN/TAKE-OUT/DRIVE-THU KEY PROGRAMMING	59
PRINT KEY PROGRAMMING ⁰⁰	60
NO SALE KEY PROGRAMMING.....	61
CHECK CASHING KEY PROGRAMMING	62
TIME IN/OUT KEY PROGRAMMING	63
P/BAL KEY PROGRAMMING	64
CHECK # KEY PROGRAMMING	65
TABLE # KEY PROGRAMMING.....	66

GUEST # KEY PROGRAMMING	67
SERVICE KEY PROGRAMMING	68
PRINT CHECK / SLIP PRINT KEY PROGRAMMING	69
TIP KEY PROGRAMMING.....	70
MACRO KEY PROGRAMMING	71
ADD, DEDUCT & STOCK OVERWRITE KEYS	72
PLU PROGRAMMING.....	73
DEPARTMENT PROGRAMMING	82
NON PLU PROGRAMMING.....	87
PLU PLACEMENT PROGRAMMING (NLU PROGRAMMING)	88
SET MENU PROGRAMMING.....	88
MIX & MATCH TABLE PROGRAMMING	90
CLERK PROGRAMMING.....	91
GROUP PROGRAMMING.....	92
KITCHEN PRINTER ROUTE PROGRAMMING ⁰⁰	93
MESSAGES ⁰⁰	94
FINANCIAL REPORT MESSAGE PROGRAMMING.....	94
DISPLAY / PRINT DESCRIPTOR PROGRAMMING.....	94
ERROR MESSAGE PROGRAMMING	94
MESSAGES ⁰⁰	95
CLERK REPORT MESSAGE PROGRAMMING.....	95
LOGO MESSAGE PROGRAMMING.....	95
DISPLAY PRINT DESCRIPTOR DEFINITIONS	96
ERROR MESSAGE DESCRIPTOR DEFINITIONS	98
STRING REPORT PROGRAMMING.....	100
TIME SCHEDULE FOR STRING REPORT	101
MENU LEVEL SCHEDULE PROGRAMMING	101
TIME SCHEDULE FOR STRING REPORT	102
RESET TIME SCHEDULAR.....	102
RESET MENU SCHEDULAR.....	102
DATE AND TIME PROGRAMMING	103
PROGRAM DOWNLOAD.....	104

OPERATION

FUNCTION OF MODE CONTROLS	107
KEY DESCRIPTION	107
KEY DESCRIPTION	109
KEY DESCRIPTION	110
KEY DESCRIPTION	111
CLERK SIGN ON	112
CLERK SIGN ON/OFF	112
CLERK SIGN ON	113
CLERK REGISTRATION MODE	113
FLOATING CLERK SYSTEM	113
ITEM SALE ENTRIES	114
REPEAT ENTRIES	115
SPLIT PRICING ENTRIES	116
FINALIZING OF TRANSACTION	117
MIXED TENDERING	118
TAX OPERATION	119
EXEMPTING TAX	120
R/A AND P/O FUNCTION	121
PRICE CHANGE	122
NOT FOUND PLU	123
PRICE ENQUIRY	124
PRICE SHIFT	125
LEVEL SHIFT (ONLY FOR DIRECT PLU)	126
LINK PLU ENTRIES	127
MIX AND MATCH OPERATION	128
CORRECTIONS	129
REFUND FUNCTION	129
ALL VOID	130
PROMO & WASTE	130
WASTE	131

OTHER ENTRIES	131
PERCENT OPERATION.....	132
DISCOUNT AMOUNT.....	133
NON ADD # ENTRY.....	134
CURRENCY EXCHANGE	135
CHECK OPERATION.....	136
BILL ADDITION.....	137
CLERK INTERRUPT OPERATION.....	138
CLERK SIGN OFF FOR CLERK INTERRUPT OPERATION.....	139
TRAINING MODE.....	140
RECEIPT ISSUE	141

REPORTS

REPORTS	143
REPORT LIST	144
REPORTS	144
CONSOLIDATING REPORTS	144
CONSOLIDATING REPORTS	144
REPORT LIST	145

ERROR MESSAGES

ERROR MESSAGE DESCRIPTOR DEFINITIONS	150
TRANSMISSION ERRORS	152

Important Notations

⁰⁰ : SER6500 only.

⁴⁰ : SER6540 only.

Ribbon cassette installation

1. Before inserting ribbon cassette (②), turn knob (①) counterclockwise to prevent twisting the ribbon.
2. After inserting the ribbon cassette (②) at the center (③) of the printer, turn the knob (①) counterclockwise again to make sure the ribbon moves freely in the cassette.

Receipt/journal paper insertion

1. Using a new roll of paper, unroll the paper about 150mm and fold the paper as shown in the right figure.
2. Insert folded paper into the chute (②) of the ERP300V printer. While holding the lever (①) down, pull the paper out until the fold point (③) is completely out of the printer. And turn the knob (④) counterclockwise.
3. Cut the receipt paper.
4. Insert the journal paper into the slit (③) of the rewind spindle. Wind the spindle three or four times.
5. Push end disk (④) onto the spindle as shown in the right figure.
6. Insert the spool to the printer part (⑤).
7. when the journal paper is loose, rewind the spindle to tighten the paper.

ALL CLEAR PROCEDURE

Turn key to S-Mode. Unplug the register, hold down the third key up from the lower right key on the keyboard, while holding down this key plug the register back in. An all clear keyboard receipt is issued.

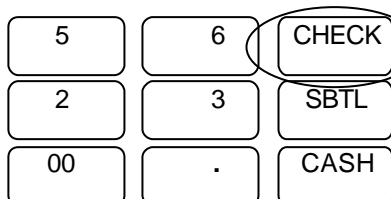

Use this key for all clear procedure regardless of what key function is programmed at that location

REGI NO.	<input type="text" value="X/TIME"/>	: This machine's register no.
DDMMYYHHMM	<input type="text" value="X/TIME"/>	: Current date and time.
Z3(SER6500) / Z2(SER6540)	<input type="text" value="X/TIME"/>	: If you press "1" and X/TIME key the ECR makes Z3/Z2 report area. Otherwise it will not make Z3/Z2 area.
NO. OF CLERKS	<input type="text" value="X/TIME"/>	: Enter no. of clerks. If you press only X/TIME key then machine's no. of clerk will be one.
CHECK TYPE	<input type="text" value="X/TIME"/> *	: If you press "1" and X/TIME key, the check type will be SOFT CHECK. Otherwise it will be HARD CHECK.
CHECK LINE	<input type="text" value="X/TIME"/> *	: If you select check type as SOFT CHECK, it requires CHECK LINE.
NO. OF CHECKS	<input type="text" value="X/TIME"/>	: Enter no. of checks. If you press only X/TIME key then no. of check will be zero.
CLERK INT	<input type="text" value="X/TIME"/>	: If you press "1" and X/TIME key, this machine will allocate memory for clerk interrupt / floating clerk.
PLU STOCK	<input type="text" value="X/TIME"/>	: If you press "1" and X/TIME key, this machine will allocate memory for stock
NO. OF PLUs	<input type="text" value="X/TIME"/>	: Enter no. of PLU. If you press only X/TIME key then no. of PLU will be automatically set the maximum

* There are two check types. HARD CHECK and SOFT CHECK.

HARD CHECK carries only sales amount No Detail of the bill are stored.

SOFT CHECK carries all information regarding a check, this option would normally be used where full detail of the check is required.

** CHECK LINE means the no. of detail lines which contain sales information. i.e. number of items sold on a bill. HARD CHECK only hold the sales amount, so if your check type is HARD CHECK it does not require "Check Line" preset and skips this part.

INITIAL CLEAR & DEFAULT KEY BOARD

Initial clear

Turn key to P-Mode. Unplug the register, hold down the lower right key on the keyboard, while holding down this key plug the register back in. An initial clear receipt should be issued.

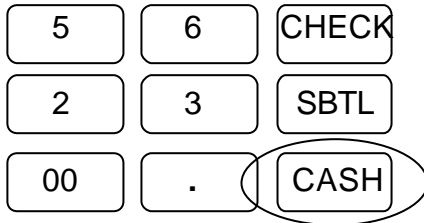

Use this key for initial clear procedure regardless of what key function is programmed at that location

Note : After initial clear procedure the working memory is cleared.
Working memory means all data memory except report and program file.
So, if you were in the middle of transaction, the transaction is canceled.

Install default keyboard

Turn key to S-Mode. Unplug the register, hold down the second key up from the lower right key on the keyboard, while holding down this key plug the register back in. An install default keyboard receipt is issued.

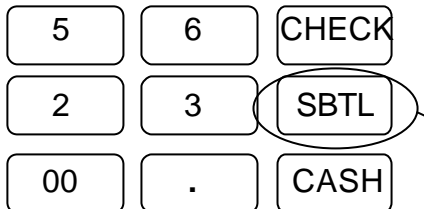

Use this key for install default keyboard procedure regardless of what key function is programmed at that location

S-MODE

SERVICE FUNCTIONS

S-POSITION SERVICE FUNCTIONS

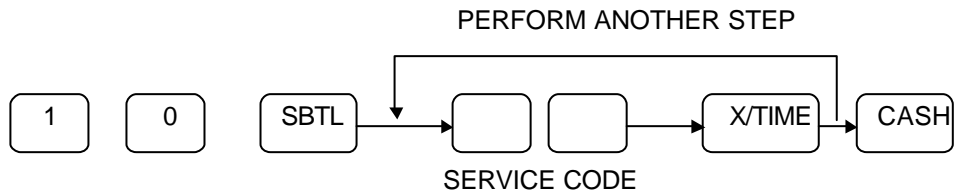

CODE	FUNCTION
1	All reports and grand totals clear*
2	Clear reports only*
3	Clear grand totals only*
4	Printer test
5	Printer dot alignment test
6	Display test
7	Ram test
8	EPROM checksum print out
9	S-mode programming print out
10	Clear plu file*
11	Check unlock**
12	Clerk unlock***
13	Pole display test
14	Reset receipt consecutive no.*

* Press 1 - to go on, or press to cancel.

** Press check# -

*** Press clerk# - for floating clerk system,
 or press regi# - - clerk# - for non - floating clerk system.

Register number programming

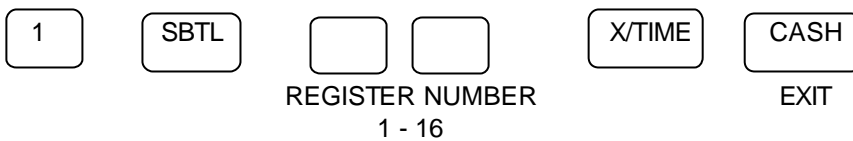

Setting Level Stay Down

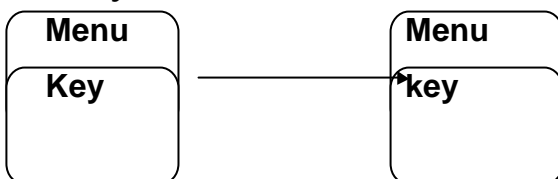

COMMUNICATIONS SETTINGS

S-POSITION COMMUNICATION TEST

PERFORM ANOTHER STEP

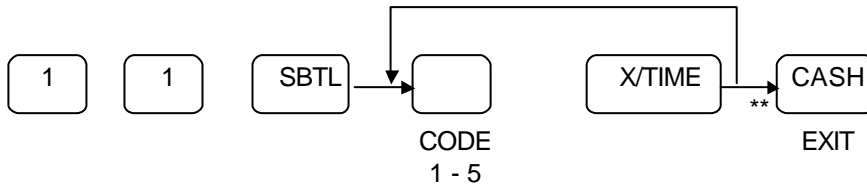

CODE	FUNCTION
1	Test serial port #1 *
2	Test serial port #2 *
3	Test serial port #3 *
4	Test serial port #4 *
5	IRC test
6	System Wide IRC test **

* Requires hardware strap on serial connector

** After Pressing X/TIME You must enter the Number of the register that you wish to test communications to, and Press SUBTOTAL. If no error is found the display will return to PORT/IRC. Detailed error code will be printed on the audit roll.

Details of The messages printed on the audit roll can be found at the back of this manual.

Loop Back Test Connections

1: Serial Ports 1 and 2 (9 Pin D Type)

TXD(3) ----- RXD(2)
 DTR(4) ----- DSR(6)
 CTS(8) ----- RTS(7)

2: Serial Ports 3 and 4 (Modular)

TXD(3) ----- RXD(4)
 DTR(8) ----- DSR(2)
 CTS(6) ----- RTS(5)

FUNCTION KEYS

S-MODE KEY RELOCATION PROGRAMMING

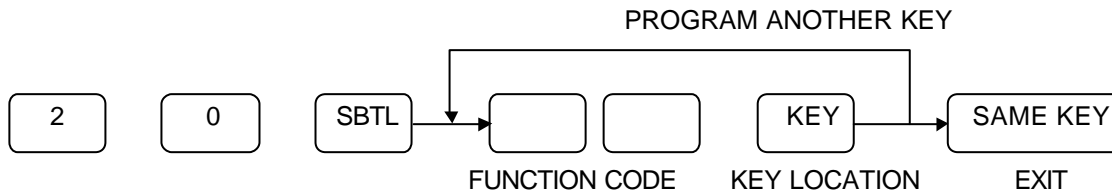

CODE	FUNCTION	CODE	FUNCTION	CODE	FUNCTION
0	N/A	41	TAX SHIFT	84	SET MENU #
1	CASH	42	ADD CHECK	85	NOT FOUND PLU
2	CHEQUE	43	NEW CHECK	86	2 ND PRICE
3	CHARGE #	44	TRANSFER CHECK	87	LEVEL #1
4	CHARGE1	45	SUBTOTAL	88	LEVEL #2
~		46	X/TIME	89	LEVEL #3
11	CHARGE8	47	VALID	90	NUMERIC 0
12	CUR CONV1	48	P/BAL	~	
13	CUR CONV2	49	CHECK #	99	NUMERIC 9
14	%1	50	TABLE #	100	NUMERIC 00
~		51	GUEST #	101	NUMERIC 000
23	%10	52	SERVICE	102	DECIMAL(.)
24	ERR CORRECT	53	PRINT CHECK	130	ADD STOCK
25	VOID	54	CHARGE TIP	131	DEDUCT STOCK
26	CANCEL	55	SLIP PRINT	132	STOCK OVERWRITE
27	P/O	56	PRICE CHANGE	133	STOCK ENQUIRY
28	R/A	57	OPEN PRICE	135	CUR CONV3
29	MDSE RETN	58	PRICE ENQUIRY	136	CUR CONV4
30	EXEMPT TAX	59	MACRO 1	140	INACTIVE
31	EAT IN	~		150	SET MENU 1
32	TAKE OUT	68	MACRO 10	~	
33	DRIVE THROUGH	69	CLERK #1	179	SET MENU 30
34	PRINT ⁰⁰	~		200	PLU 1
35	# / NO SALE	78	CLERK #10	~	
36	CHEQUE-CASH	79	CLEAR	319	PLU 120
37	PROMO	80	PLU #	600	DEPT 1
38	WASTE	81	DEPT #	~	
39	TIME IN/OUT	82	POST RECEIPT	639	DEPT 40
40	CASHIER	83	RECEIPT ON/OFF		

FIXED LOCATIONS

RECEIPT FEED

DETAIL FEED

RECEIPT ON/OFF

KEY DESCRIPTION

Numeric Keys :

0,1,2,3,4,5,6,7,8,9,00 are used to input numeric data (amount, quantity, program codes etc.)

Cash Key

This key is used to finalize a Cash transaction. When it is pressed, the total amount of the transaction is calculated. At the same time, a receipt can be issued and the Cash Drawer opened. The total amounts are added to the specific reports as applicable. If the amount tendered is entered into the register and this exceeds the total amount of the sale then the change will be calculated and displayed on the screen.

Cheque Key

This key is used to finalize a Cheque transaction. If the amount tendered is entered into the register and this exceeds the total amount of the sale then the change will be calculated and displayed on the screen.

Charge# key

This key is used to finalize one of eight types of Charge transaction.

Charge 1 ~ 10 keys

These keys are used to finalize a Charge transaction. Up to 10 Charge keys are available.

Cur Conv1 and Cur Conv2 keys

The Currency conversion keys are used to convert a subtotal figure into foreign currency using an exchange rate preset to each key. When this key is pressed, the register enters the currency exchange mode, and subsequent amount entries are regarded as foreign currency.

%1 - %10 keys. (Discount, surcharge etc.)

These keys can be programmed for monetary discount, monetary surcharge, percentage discount and percentage surcharge, etc.

Err Correct key

This key is used to invalidate the immediately preceding registration. The key must be pressed immediately after the incorrect entry.

Void key

This key is used to invalidate previously registered data. This operation must be made before the end of the transaction.

Cancel key

This key is used to completely cancel the last sale. If a transaction is canceled none of the totals are updated.

P/O key

This key is used to record amounts paid out from the register. Amounts Paid Out will be deducted from Cash In Drawer total.

R/A key

This key is used to register cash received other than sales transactions. Amounts Received On Account will be added to the Cash In Drawer total.

MDSE Return key

This key is used to register refunded goods in the registration position. This function is available for returns to Departments and PLU's. It will also return any tax which may be applicable.

KEY DESCRIPTION

Exempt Tax key

This key is used to change the tax status of the proceeding sale item.

Eat In /Take Out/Drivethru keys

These keys are used to provide sales data on the various type of transaction. i.e. where the goods are taken out?. For areas that have different tax rules the tax charges may be exempt.

Print key

This key enables any items to be printed to a kitchen printer even when the item is not preset to print to a printer.

/ No sale key

The #/No Sale key is used as a non-add key, and prints up to a 7 - digit numeric entry on the receipt and journal. This entry will not add to any sales total. The #/No Sale key is also used for No Sale operations to simply open the cash drawer.

Cheque - Cash key

This key is used to Cash Cheques and provide a facility to transfer sales information from/to the necessary totalizers

Promo key

This key is used to sell an items at no charge.

Waste key

This key is used to write off items.

Time In/Out key

This key is used to Clock In / Out clerks. Information regarding the hours a clerk has worked is stored in the registers memory.

Cashier#

This key is used to sign on/off a cashier. Either by Cashier Number or Secret Cashier Number.

Tax Shift

When this key is depressed before a department or PLU, the tax shift key reverses the tax shift of the department/PLU. i.e. a PLU with no tax status could be preset with Tax1, Tax2..... or All.

Add Check

This key is used to add a number of checks together

Separate Check

This key is used to separate a check so that the check can be paid for by a number of people.

Transfer Check

This key is used to transfer one check to another check number.

Sub-Total

This key displays the total of the sale including any tax calculation. It can be preset as compulsory if required.

X/Time

This key is used as a multiplication key or for displaying the time and date on the display.

Valid

This key is used to print a one line validation through the receipt/journal printer.

KEY DESCRIPTION

P/Bal

This key is used to input a previous balance.

Check#

This key is used in the check system to input a check number. The ECR can be programmed to generate a unique check number.

Table#

This key is used to enter a table number that can be printed on the customer bill or kitchen printer.

Guest#

This key is used to enter the number of guests at a table.

Service

This key is used to close transactions temporarily in a check system.

Print Check

This key is used to print the details of a check to either the receipt or bill printer.

Charge Tip

This key is used to input an amount of tips received.

Slip Print

This key is used to print the details of a check to the slip printer.

Price Change

This key enables the clerk to adjust the preset price of an item.

Open Price

This key is used to enter a price against an open PLU.

Price Enquiry

This key is used to enquire on the price of a item without registering the item.

Macro 1 ~ 10 Keys

Macro keys are used to execute a preset number of keystrokes automatically. A Macro can include another Macro if required.

Clerk#1 ~ 10 Keys

The clerk keys are used to sign a clerk on / off the ECR. They are also used for clerk interrupt operation.

Clear Key

Used to clear entries made on the keyboard. It is also used to clear error tones.

PLU#

This key is used to enter PLU (price look-ups) codes or bar-codes.

Dept#

This key is used to enter sales against a department that does not appear on the keyboard.

Post Receipt

If the receipt was turned off during a sale, this key will issue a receipt after the sale has been completed.

Receipt On / Off

Turns the Receipt On / Off

Set Menu#

Used to sell a Set Menu that is not on the keyboard.

KEY DESCRIPTION

Not Found PLU

If a PLU or barcode is not set-up on the ECR and an attempt is made to sell the product, by pressing the Not Found key the item can be programmed during registration for subsequent sales.

2nd Price

This key is used to sell the PLU or Barcode item at its second price.

Level #1, Level #2 and Level #3

These keys are used to change between menu levels

Set Menu 1 ~ 10

Used to sell a Set Menu item.

PLU 1 ~ 120

Used to assign a specific PLU number to the keyboard.

Dept 1 ~ 40

Used to assign a specific department to the keyboard.

S-MODE SYSTEM OPTIONS

OPTION PROGRAMMING

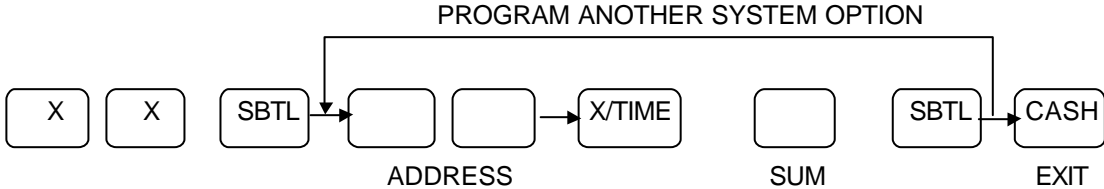

Option	XX	Mode
S-mode system options	30	S

S-MODE SYSTEM OPTIONS - 30

Addr.	Meaning	VALUE	=	SUM
1	Base Currency is: (Euro Eprom Only)	Local = 0 Euro = 4	A	A+B+C
	Print Gross Sales Grand Total on financial report.	YES = 2 NO = 0	B	
	Reset Gross Sales Grand Total after z-financial report.	YES = 1 NO = 0	C	
2	Tax totals do not add to the net sales grand total	YES = 4 NO = 0	A	A+B+C
	Print Net Sales Grand Total on financial report.	YES = 2 NO = 0	B	
	Reset Net Sales Grand Total after z-financial report.	YES = 1 NO = 0	C	
3	Print Negative Sales Grand Total on financial report.	YES = 2 NO = 0	A	A+B
	Reset Negative Sales Grand Total after z-financial report.	YES = 1 NO = 0	B	
4	If print grand totals on Z-Reports also print on X-Reports.	YES = 1 NO = 0	A	A+B+C
	Allow stock reset report (Report will still print but not clear)	YES=2 NO = 0	B	
	PLU sales do not deduct from current stock	YES = 4 NO = 0	C	
5	Consecutive number resets after Z financial report.	YES = 2 NO = 0	A	A+B
	Z-Counter resets after Z financial reports.	YES = 1 NO = 0	B	
6	VAT tax is subtracted from individual PLU/ DEPT totals.	YES = 1 NO = 0	A	A
7	Stop Consecutive No. in Training Mode	YES = 1 NO = 0	A	A+B+C
	Consecutive No. does not increase on Post Receipt / Bill Print operations	YES = 2 NO = 0	B	
	BILL PRINT / POST receipt printed on Audit roll when these operations are carried out	YES = 4 NO = 0	C	
8	Do not add VOID mode totals to the grand totals	YES = 2 NO = 0	A	A+B
	Deactivate void mode.	YES = 1 NO = 0	B	
9	Disable programming of date & time	YES = 2 NO = 0	A	A+B
	Time that prints on receipt is	AM/PM = 1 MILITARY = 0	B	

S-MODE SYSTEM OPTIONS - 30

Addr.	Meaning	VALUE	=	SUM
10	Decimal Position is :	X.XX = 0 XX.X = 1 XXX. = 2 X.XXX = 3		
11	Send item to KP when subtotal is pressed ⁰⁰	YES = 4 NO = 0	A	A+B+C
	KP/KV feature is ⁰⁰	real time = 2 batch = 0	B	
	KP/KV prints/displays the total of the sale? ⁰⁰ (batch mode only)	YES = 1 NO = 0	C	
12	Stop Condiment printing on Slip/Bill	YES = 1 NO = 0	A	A
13	Stop Item consolidation on KP	YES = 4 NO = 0	A	A+B+C
	Train mode does not print at the beginning of receipt during training.	YES = 2 NO = 0	B	
	Does not print KP/KV in void mode ⁰⁰	YES = 1 NO = 0	C	
14	Do not print training total on financial report	YES = 1 NO = 0		
15	Soft check print at tender is stub	YES = 2 NO = 0	A	A+B
	Allow open check report in z mode	YES = 1 NO = 0	B	
16	PLU level is	Stay down = 0 Item popup = 1 Ticket popup = 2	A	A+B
	Level shift in X mode only	YES = 4 NO = 0	B	
17	Price level is	Stay down = 0 Item popup = 1 Ticket popup = 2	A	A+B
	Price shift in X mode only	YES = 4 NO = 0	B	
18	One out of EAT IN, TAKE OUT or DRIVE THROUGH is compulsory before tender	YES = 1 NO = 0		

P-MODE

ALPHANUMERIC CHARACTERS

Using direct character key on keyboard.

- Normal characters can be made by pressing each character keys.
- To make character as double size, use Double key on keyboard.

Example

Double C O M E Double A N D Double S E E

- To make a small letter entry, use CAPS key.

Example

S CAPS M A L L

- To modify incorrect character entry, use BKSP key.

Example

W E L C O M W BKSP E

Using character code

90key KBD can not contain all characters on keyboard.

But you can make an character entry which is not on current 90key keyboard, by using character code entry.

To make an character code entry, simply enter 3-digit code continuously.

This method is also available for 160key KBD.

Example

To program the word "Two £" where space exist between Two and £, and £ as a double character.

084 119 111 032 003 156

(Refer to the character code table)

CHARACTER CODES

SER 6500/40 CHARACTER CODE TABLE

CHAR	CAPS	Doubl e	Tx	Fs	SPACE	!	"	#	\$	%
CODE	001	003	030	031	032	033	034	035	036	037
CHAR	&	'	()	*	+	,	-	.	/
CODE	038	039	040	041	042	043	044	045	046	047
CHAR	0	1	2	3	4	5	6	7	8	9
CODE	048	049	050	051	052	053	054	055	056	057
CHAR	:	;	<	=	>	?	@	A	B	C
CODE	058	059	060	061	062	063	064	065	066	067
CHAR	D	E	F	G	H	I	J	K	L	M
CODE	068	069	070	071	072	073	074	075	076	077
CHAR	N	O	P	Q	R	S	T	U	V	W
CODE	078	079	080	081	082	083	084	085	086	087
CHAR	X	Y	Z	[\]	^	_	`	a
CODE	088	089	090	091	092	093	094	095	096	097
CHAR	b	c	d	e	f	g	h	i	j	k
CODE	098	099	100	101	102	103	104	105	106	107
CHAR	l	m	n	o	p	q	r	s	t	u
CODE	108	109	110	111	112	113	114	115	116	117
CHAR	v	w	x	y	z	{		}	~	
CODE	118	119	120	121	122	123	124	125	126	127
CHAR	ç	ü	é	â	ä	à	á	ç	ê	ë
CODE	128	129	130	131	132	133	134	135	136	137
CHAR	è	ï	î	ì	Ä	Å	É	æ	Æ	ô
CODE	138	139	140	141	142	143	144	145	146	147
CHAR	ö	ò	û	ù	ÿ	Ö	Ü	ç	£	¥
CODE	148	149	150	151	152	153	154	155	156	157
CHAR	Ɔ	ƒ	á	í	ó	ú	ñ	Ñ	ª	º
CODE	158	159	160	161	162	163	164	165	166	167
CHAR	¿	▪	ª	ß	€					
CODE	168	169	170	171	186					

CHARACTER MAP

SER 6500 KEY CHARACTER MAP

			â	ê	î	ô	û	ä	ë	ï	ö	ü	Ä	Ö	Ü
Å	å	É	à	è	ì	ò	ù	á	é	í	ó	ú	Æ	æ	ÿ
Ç	ç	¢	ª	º	Ñ	ñ	Þ	ƒ	¿	T _X	F _S	£	¥	ß	
!	@	#	\$	%	^	&	*	()	-	+	“			
Q	W	E	R	T	Y	U	I	O	P	<	>				
A	S	D	F	G	H	J	K	L	;	`	?				
Z	X	C	V	B	N	M	,	▪	/	:	=	7	8	9	
CAPS		SP	SP	SP	SP	SP	CAPS	Doubl e	BKSP			4	5	6	
												1	2	3	
												0	00	.	

SER 6540 KEY CHARACTER MAP

			K	M	N	O	P	U	V	#	*	()	?
A	F		L				Q		W		£*		-	=
B	G	7	8	9			R		X		%		+	/
C	H	4	5	6			S		Y		@		BKSP	,
D	I	1	2	3			T		Z		&			
E	J	0					CAPS		SP		Dbl			

* Depend on the currency symbol option setting, this key will show programmed currency symbol.

PROGRAM ACCESS CODES LIST

15	PROGRAM SCAN
40	P-MODE OPTION PGM
50	PRINTING OPTION PGM
60	PERIPHERAL OPTION PGM
70, 71, 75	FUNCTION KEY STATUS PGM
72	TAX PROGRAMMING
80, 81	FUNCTION KEY DESCRIPTOR PGM
90, 91	FUNCTION KEY HALO PGM
95	MACRO PGM
100	DIRECT PLU ADD / MODIFY
110	DIRECT PLU DELETE
120	DIRECT PLU STATUS PGM
121	DIRECT PLU PRICE PGM
122	DIRECT PLU DESCRIPTOR PGM
123	DIRECT PLU LINK PLU PGM
124	DIRECT PLU LINK DEPT. PGM
125	DIRECT PLU LINK M&M PGM
126	DIRECT PLU KP PGM ⁰⁰
200	BATCH PLU ADD / MODIFY
210	BATCH PLU DELETE
220	BATCH PLU CLEAR
230	RUN BATCH PLU
300	DEPARTMENT ALL PGM
320	DEPARTMENT STATUS PGM
321	DEPARTMENT PRICE PGM
322	DEPARTMENT DESCRIPTOR PGM
324	DEPARTMENT LINK GROUP PGM
326	DEPARTMENT KP PGM ⁰⁰
400	NON-PLU PGM ⁴⁰
500	PLU PLACEMENT PGM
600	SET MENU PGM
700	MIX & MATCH TABLE PGM
800	CLERK CODE PGM
810	CLERK DESCRIPTOR PGM
820	CLERK STATUS PGM
830	LABOUR GROUP DESCRIPTOR PGM
900	GROUP DESCRIPTOR PGM
910	GROUP STATUS PGM
930, 935	KP / KV ROUTE PGM ⁰⁰
940	KP / KV DESCRIPTOR PGM ⁰⁰
1000	FINANCIAL MESSAGE PGM
1010	DISPLAY MESSAGE PGM
1020	ERROR MESSAGE PGM
1030	CLERK MESSAGE PGM
1100	LOGO PGM
12XX	STRING REPORT PGM
1300	TIME SCHEDULE PGM
1350	MENU LEVEL SCHEDULE PGM
1400	TIME & DATE SET
1401	DATE SET
1402	TIME SET
9999	PROGRAM DOWNLOAD

PROGRAMMING SCANS

P-POSITION PROGRAMMING SCANS

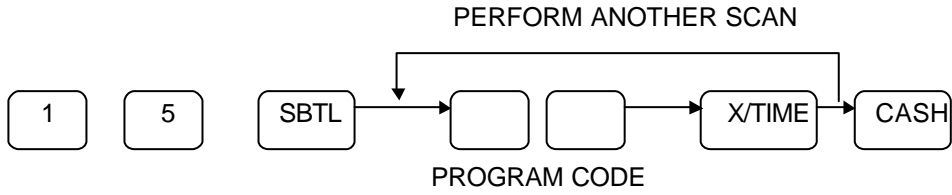

CODE	FUNCTION	
1	P-mode options	
2	Printing options	
3	Communication options	
4	Function keys	
5	Keyboard layout	
6	Range plu's	Start PLU# PLU code key Ending PLU# PLU code key or Push starting assigned PLU key Push ending assigned PLU key
7	Clerks	
8	Tax programming	
9	Macro programming	
10	Normal group programming	
11	Labour group programming	
12	Display message	
13	Financial report messages	
14	Logo message	
15	Error message	
16	Clerk report message	
17	String report	
18	Time schedule	
19	KV/KP route ⁰⁰	
20	NLU	
21	Department	
22	Mix & match table	
23	Batch PLU	
24	Non PLU ⁴⁰	
25	Set menu	
26	Menu level schedule	

P-MODE SYSTEM OPTIONS

OPTION PROGRAMMING

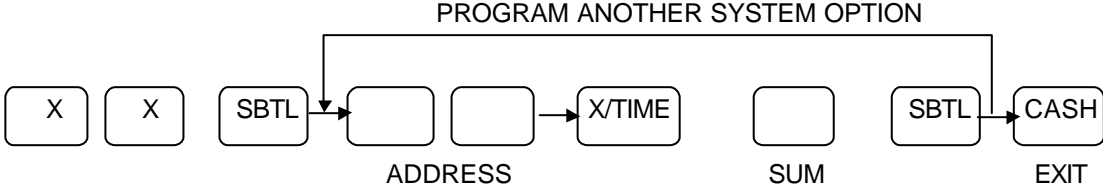

<u>Option</u>	<u>XX</u>	<u>Mode</u>
P-mode system options	40	P
P-mode printing options	50	P
P-mode communications options	60	P

P-MODE SYSTEM OPTIONS - 40

Addr.	Meaning	VALUE	=	SUM
1	Cash Declaration is compulsory before X/Z reports. (Only required on Master in IRC System)	YES = 2 NO = 0	A	A+B+C
	Cash drawer does not open when reports are run.	YES = 1 NO = 0	B	
	Open EURO currency drawer as well as HOME currency drawer	YES = 4 NO = 0	C	
2	Zero sales are not allowed.	YES = 4 NO = 0	A	A+B+C
	Negative sales are not allowed.	YES = 2 NO = 0	B	
	Allow Post Tender Function.	YES = 1 NO = 0	C	
3	Open drawer.	YES = 2 NO = 0	A	A+B+C
	Open Drawer alarm is activated.	YES = 1 NO = 0	B	
	Subtract change from Foreign#1 (EURO) Total	YES = 4 NO = 0	C	
4	Number of seconds before the open drawer alarm SOUNDS (default value = 30)	1 - 99		
5	Enable floating clerk	YES = 4 NO = 0	A	A+B+C
	Clerks are :	Popup = 2 Stay down = 0	B	
	Clerk sign on is from KBD or from real clerk key	Real clerk key = 1 KBD = 0	C	
6	Rounding at tender is 0.00~0.02 : 0.00 / 0.03~0.07 : 0.05 / 0.08~0.09 : 0.10 0.00~0.24 : 0.00 / 0.25~0.74 : 0.50 / 0.75~0.99 : 1.00 0.00~0.04 : 0.00 / 0.05~0.09 : 0.10	Inactive = 0 European = 2 Swedish = 4 Finnish = 6	A	A+B
	Descriptor PGM is from alpha-numeric key on KBD or from character code.	code = 1 KBD = 0	B	
7	% and Tax calculations will :	round up at .50= 0 round up = 1 round down = 2		
8	Rounding factor for split pricing and decimal multiplication.	round up at .50= 0 round up = 1 round down = 2		
9	Hash feature is :	Normal = 1 Non-add = 0	A	A
10	Maximum digit entry for all entries 0 = No limit	0-14		

P-MODE SYSTEM OPTIONS - 40

Addr.	Meaning	VALUE	=	SUM
11	De-activate split pricing.	YES = 2 NO = 0	A	A+B
	Allow direct multiplication.	YES = 1 NO = 0	B	
12	PLU/DEPT NO. is automatically increased.	YES = 1 NO = 0	A	A
13	Disable DEPT. preset/HALO override.	YES = 2 NO = 0	A	A+B
	Disable PLU preset/HALO override.	YES = 1 NO = 0	B	
14	Drawer is opened in training mode.	YES = 2 NO = 0	A	A+B
	Orders are sent to kitchen in training mode? ⁰⁰	YES = 1 NO = 0	B	
15	Activate paper near end sensor	YES = 2 NO = 0	A	A+B
	Activate validation sensor	YES = 1 NO = 0	B	
16	Cash in drawer limit	1-9999999		
17	Standard labour rate	1-9999		
18	Password for training mode. (1111 by default)	0001-9999		
19	No beep on key depressions.	YES = 1 NO = 0	A	A
20	Compulsory SUBTOTAL when finalizing CHECK	YES = 4 NO = 0	A	A+B+C
	Compulsory SUBTOTAL when overlap clerk cash off.	YES = 2 NO = 0	B	
	Enable clerk interrupt	YES = 1 NO = 0	C	
21	Cheque change HALO	0-99999999		
22	Disable Group link compulsory in DEPT programming	YES = 4 NO = 0	A	A+B+C
	DEPT. link entry skip in Not Found PLU programming	YES = 2 NO = 0	B	
	Description entry skip in not found PLU programming.	YES = 1 NO = 0	C	
23	Clerk #1 code is (1 - 99, default is 1)			
~				
32	Clerk #10 code is (1 - 99, default is 10)			
33	Clerk sign on/off is using	Clerk no. = 1 Secret code = 0		

P-MODE PRINTING OPTIONS - 50

Addr.	Meaning	VALUE	=	SUM
1	Subtotal without tax will be printed on receipt.	YES = 2 NO = 0	A	A+B
	Tax amount charged will not print on receipt on tender.	YES = 1 NO = 0	B	
2	Print taxable totals.	YES = 2 NO = 0	A	A+B
	Value Added Tax (VAT) will print a separate line.	YES = 1 NO = 0	B	
3	Tax amount to be printed on receipt at tender is :	Combined = 1 Itemized = 0	A	A+B
	Stop All Printing in Training Mode	YES = 2 NO = 0	B	
4	Print Department report at beginning of financial report.	YES = 4 NO = 0	A	A+B+C
	Print abbreviated Financial report.	YES = 2 NO = 0	B	
	Print "ABBREVIATED" on top of abbreviated reports.	YES = 1 NO = 0	C	
5	Does not print audaction on financial report	YES = 4 NO = 0	A	A+B+C
	Print media totals with zero activity on financial report.	YES = 2 NO = 0	B	
	Print total labour cost on financial report.	YES = 1 NO = 0	C	
6	Print Group report at beginning of financial report.	YES = 4 NO = 0	A	A+B+C
	Print PLU report at beginning of financial report.	YES = 2 NO = 0	B	
	Print clerk report at end of financial report.	YES = 1 NO = 0	C	
7	Print average sales amount per item on financial report.	YES = 4 NO = 0	A	A+B+C
	Print average sales amount per customer on financial report.	YES = 2 NO = 0	B	
	Print average item per customer on financial report.	YES = 1 NO = 0	C	
8	Inhibit printing time on receipt and detail.	YES = 4 NO = 0	A	A+B+C
	Inhibit printing date on receipt and detail.	YES = 2 NO = 0	B	
	Skip positive entries on detail.	YES = 1 NO = 0	C	

P-MODE PRINTING OPTIONS - 50

Addr.	Meaning	VALUE	=	SUM
9	Does not print consecutive # in receipt/detail	YES = 4 NO = 0	A	A+B+C
	Stop all printing on detail.	YES = 2 NO = 0	B	
	Print subtotal when subtotal key is depressed.	YES = 1 NO = 0	C	
10	Check validation amount is :	Total = 2 Tender = 0	A	A+B
	Final validation amount is :	Total = 1 Tender = 0	B	
	Partial cut in barcode printing	YES = 4 NO = 0		
11	Stop time printing on Slip Bill	YES = 4 NO = 0	A	A+B+C
	Stop date printing on Slip Bill	YES = 2 NO = 0	B	
	The date format will be printed in form of :	mm/dd/yyyy = 1 dd/mm/yyyy = 0	C	
12	Does not print audaction on clerk report	YES = 4 NO = 0	A	A+B+C
	Print media totals on cashier report.	YES = 2 NO = 0	B	
	Print sales % on reports.	YES = 1 NO = 0	C	
13	Allow multiple receipts	YES = 2 NO = 0	A	A+B
	Allow multiple validations.	YES = 1 NO = 0	B	
	Redirect Receipt Printing to Remote Printer (V1.56)	YES = 4 NO = 0		
14	Do not print SERVICE on Bill	YES = 4 NO = 0	A	A+B+C
	Stop Clerk Name printing on Slip Bill	YES = 2 NO = 0	B	
	Buffered receipt is :	STUB = 1 FULL = 0	C	
15	Logo will print as :	Pre-amble = 4 Post-amble = 2 STAMP = 1 NONE = 0		

P-MODE PRINTING OPTIONS - 50

16	Print PLU code on PLU report.	YES = 4 NO = 0	A	
	Print PLU code with the item descriptor.	YES = 2 NO = 0	B	
	Print zero totals on all reports other than financial.	YES = 1 NO = 0		
17	Time worked will print in	HHMM = 2 100's = 0	A	A+B
	Time worked will be printed when clerks clock-out.	YES = 1 NO = 0	B	
	Enable barcode printing to SRP300 (V1.56)	YES = 4 NO = 0		
18	Receipt feeds this number of lines after the total/change lines	0-10		
19	Print current stock on standard PLU report	YES = 4 NO = 0		A+B+C
	Print PLU usage on PLU report.	YES = 2 NO = 0	B	
	Print individual linked dept. on PLU report.	YES = 1 NO = 0	A	
20	Stock Value @Retail prints on STOCK report	YES = 4 NO = 0	C	A+B+C
	Stock Value @Cost prints on STOCK report { Assumes 2nd unit price to be Cost price }	YES = 2 NO = 0	B	
	Print 2nd price total separately on Financial report	YES = 1 NO = 0	A	
21	Print total number of items at bottom of sale on detail	YES = 2 NO = 0	A	A+B
	Print total number of items at bottom of sale on receipt	YES = 1 NO = 0	B	
22	Do not print begin/exit training mode on receipt & detail	YES = 4 NO = 0	A	A+B+C
	Do not issue a receipt when a clerk is time clocking in/out	YES = 2 NO = 0	B	
	Issue a receipt when a clerk is logging on/off	YES = 1 NO = 0	C	
23	Do not print tax symbol on receipt	YES = 4 NO = 0	A	A+B+C
	Print tax exempt total on financial report	YES = 2 NO = 0	B	
	Print tax exempt descriptor and totals on receipt	YES = 1 NO = 0	B	

P-MODE PRINTING OPTIONS - 50

24	Print Kitchen Printer name(ID) ⁰⁰	YES = 4 NO = 0	A	A+B+C
	Order No. will be printed.	YES = 2 NO = 0	B	
	Receipt printer does not cut the receipt	YES = 1 NO = 0	C	
25	Do not print check at finalization. ^{**}	YES = 4 NO = 0	A	A+B+C
	Print full check at finalization. * only available on PRINT CHECK key. For progressive billing use a SLIP PRINT key	YES = 2 NO = 0	B	
	Receipt Consecutive No. is random	YES = 1 NO = 0	C	
26	Home Currency character code (€ =186, £ =156, Pts =158)*	30-186 (ASCII)	A	A
27	Conversion rate 1 currency character code (€ =186, £ =156, Pts =158)*	30-186 (ASCII)	A	A
28	Conversion rate 2 currency character code (€ =186, £ =156, Pts =158)*	30-186 (ASCII)	A	A
29	Print PLU detail on receipt in Set Menu	YES = 1 NO = 0	A	A
30	Barcode printer is attached to port (1-4) (Note this option is not transferred IRC)	1 - 4		
31	Remote printer is attached to port (1-4) (Note this option is not transferred IRC)	1- 4		

P-MODE COMMUNICATIONS OPTIONS - 60

Addr.	Meaning	VALUE	=	SUM
1	Register # that holds the clerk time I/O data	1-16		
2	IRC number of first register in IRC system.	1-16		
3	IRC number of last register in IRC system.	1-16		
4	IRC retry count (default = 10)	0 - 99		
5	Store number (default = 0000)	1 - 9999		
6	Register # that holds the check tracking data + Clerk Interrupt	1-16		
7	N/a	1-16		0
8	Activate Time Schedule report feature on REG#	1 -16	A	A
9	Checkline Time -Out			
10	IRC Report retry count (default =5)			
11	Individual Financial reports print at master during consolidation.	YES = 1 NO = 0	A	A
12	Individual SALES-TIME reports print at master during consolidation.	YES = 1 NO = 0	A	A
13	Individual PLU reports print at master during consolidation.	YES = 1 NO = 0	A	A
14	Individual CLERK reports print at master during consolidation.	YES = 1 NO = 0	A	A
15	Individual CASH IN DRAWER reports print at master during consolidation.	YES = 1 NO = 0	A	A
16	Individual CHECK IN DRAWER reports print at master during consolidation.	YES = 1 NO = 0	A	A
17	Individual DEPARTMENT reports print at master during consolidation.	YES = 1 NO = 0	A	A
18	Individual GROUP reports print at master during consolidation.	YES = 1 NO = 0	A	A
19	Individual DAILY SALES reports print at master during consolidation. ⁰⁰	YES = 1 NO = 0	A	A
20	Individual ITEM by DEPT reports print at master during consolidation.	YES = 1 NO = 0	A	A
21	Individual M & M report print at master during consolidation	YES = 1	A	A
22	Future use			
23	Future use			
24	Future use			
25	Remote Barcode image height (1 -255) default =112	(1-255)		
26	Future use			
27	Future use			
28	Future use			
29	Future use			
30	Future use			

P-MODE COMMUNICATIONS/EURO OPTIONS - 60

Addr.	Meaning	VALUE	=	SUM
31	Individual Financial reports print at slave during consolidation.	YES = 1 NO = 0	A	A
32	Individual SALES-TIME reports print at slave during consolidation.	YES = 1 NO = 0	A	A
33	Individual PLU reports print at slave during consolidation.	YES = 1 NO = 0	A	A
34	Individual CLERK reports print at slave during consolidation.	YES = 1 NO = 0	A	A
35	Individual CASH IN DRAWER reports print at slave during consolidation.	YES = 1 NO = 0	A	A
36	Individual CHECK IN DRAWER reports print at slave during consolidation.	YES = 1 NO = 0	A	A
37	Individual DEPARTMENT reports print at slave during consolidation.	YES = 1 NO = 0	A	A
38	Individual GROUP reports print at slave during consolidation.	YES = 1 NO = 0	A	A
39	Individual DAILY SALES reports print at slave during consolidation. ⁰⁰	YES = 1 NO = 0	A	A
40	Individual ITEM by DEPT reports print at slave during consolidation.	YES = 1 NO = 0	A	A
41	Individual M & M report prints at slave during consolidation	YES = 1	A	A
42	Future use			
43	Enable printing Conv1/Euro Total	YES = 1 NO = 0	A	A+B+C
	Enable printing Conv1/Euro Tendered	YES = 2 NO = 0	B	
	Enable printing Conv1/Euro CHANGE	YES = 4 NO = 0	C	
44	Disable printing FOREIGN AMOUNT	YES = 1 NO = 0	A	A+B
	Disable printing HOME AMOUNT	YES = 2 NO = 0	B	
45	Enable printing of ALL Currency Total	YES = 1 NO = 0	A	A+B+C
	Enable printing of ALL Currency TENDERED amounts	YES = 2 NO = 0	B	
	Enable printing of ALL Currency CHANGE	YES = 4 NO = 0	C	
46	Conversion rate 3 currency character code (€ =186, £ =156, Pts =158)	30 - 186	A	A
47	Conversion rate 4 currency character code (€ =186, £ =156, Pts =158)	30 - 186	A	A
48	Future use			
49	Future use			

P-MODE COMMUNICATIONS OPTIONS - 60

Addr.	Meaning	VALUE	=	SUM
50	Baud Rate for serial port #1 is :	2400 = 0 4800 = 1 9600 = 2 19.2k = 3	A	A
51	Port #1 number of stop bits :	2 = 2 1 = 0	A	A+B
	Port #1 bits per character :	7 = 1 8 = 0	B	
52	Port #1 Parity :	Even = 2 Odd = 1 None = 0		
53	Port #1 is dedicated to : (0 = Port disabled)	Port disabled = 0 PC / Polling = 1 KP / Slip = 2 KVS = 3 Scale = 4 Scanner = 5 Pole display = 7	A	A
54	Number of retry seconds for port #1 (default = 30)	1 - 999		
55	Printer Type is :	SAMSUNG 100 =2 SAMSUNG 200 =2 SAMSUNG 300 =3 CITIZEN 3540/41 =1 EPSON TM-300 =2 EPSON TM-T80 =3 EPSON TM-290II =4 EPRON TM-295 =4 STAR SP-200 =5 AVERY SCALE 10		
56	Printer feeds before printing	0 - 49		
57	Printer feeds after printing	0 - 49		
58	Maximum slip line	0 - 99		
59	Reserved for Future Use			
60	Baud Rate for serial port #2 is :	2400 = 0 4800 = 1 9600 = 2 19.2k = 3		
61	Port #2 number of stop bits :	2 = 2 1 = 0	A	A+B
	Port #2 bits per character :	7 = 1 8 = 0	B	
62	Port #2 Parity :	Even = 2 Odd = 1 None = 0		

P-MODE COMMUNICATIONS/EURO OPTIONS - 60

Addr.	Meaning	VALUE	=	SUM
63	Port #2 is dedicated to : (0 = Port disabled)	Port disabled = 0 PC / Polling = 1 KP / Slip = 2 KVS = 3 Scale = 4 Scanner = 5 Pole display = 7	A	A
64	Number of retry seconds for port #2 (default = 30)	1 - 999		
65	Printer Type is :	SAMSUNG 100 SAMSUNG 200 SAMSUNG 300 CITIZEN 3540/41 EPSON TM-300 EPSON TM-T80 EPSON TM-290II EPRON TM-295 STAR SP-200 AVERY SCALE	=2 =2 =3 =1 =2 =3 =4 =4 =5 10	
66	Printer feeds before printing	0 - 49		
67	Printer feeds after printing	0 - 49		
68	Maximum slip line	0 - 99		
69	Reserved for Future Use			

P-MODE COMMUNICATIONS/EURO OPTIONS - 60

70	Baud Rate for serial port #3 is :	2400 = 0 4800 = 1 9600 = 2 19.2k = 3		
71	Port #3 number of stop bits :	2 = 2 1 = 0	A	A+B
	Port #3 bits per character :	7 = 1 8 = 0	B	
72	Port #3 Parity :	Even = 2 Odd = 1 None = 0		
73	Port #3 is dedicated to : (0 = Port disabled)	Port disabled = 0 PC / Polling = 1 KP / Slip = 2 KVS = 3 Scale = 4 Scanner = 5 Coin changer = 6 Pole display = 7	A	A
74	Number of retry seconds for port #3 (default = 30)	1 - 999		
75	Printer Type is :	SAMSUNG 100 =2 SAMSUNG 200 =2 SAMSUNG 300 =3 CITIZEN 3540/41 =1 EPSON TM-300 =2 EPSON TM-T80 =3 EPSON TM-290II =4 EPRON TM-295 =4 STAR SP-200 =5 AVERY SCALE 10		
76	Printer feeds before printing	0 - 49		
77	Printer feeds after printing	0 - 49		
78	Maximum slip line	0 - 99		
79	Reserved for Future Use			

P-MODE COMMUNICATIONS/EURO OPTIONS - 60

Addr.	Meaning	VALUE	=	SUM
80	Baud Rate for serial port #4 is :	2400 = 0 4800 = 1 9600 = 2 19.2k = 3		
81	Port #4 number of stop bits :	2 = 2 1 = 0	A	A+B
	Port #4 bits per character :	7 = 1 8 = 0	B	
82	Port #4 Parity :	Even = 2 Odd = 1 None = 0		
83	Port #4 is dedicated to : (0 = Port disabled)	Port disabled = 0 PC / Polling = 1 KP / Slip = 2 KVS = 3 Scale = 4 Scanner = 5 Coin changer = 6 Pole display = 7	A	A
84	Number of retry seconds for port #4 (default = 30)	1 - 999		
85	Printer Type is :	SAMSUNG 100 =2 SAMSUNG 200 =2 SAMSUNG 300 =3 CITIZEN 3540/41 =1 EPSON TM-300 =2 EPSON TM-T80 =3 EPSON TM-290II =4 EPRON TM-295 =4 STAR SP-200 =5 AVERY SCALE 10		
86	Printer feeds before printing	0 - 49		
87	Printer feeds after printing	0 - 49		
88	Maximum slip line	0 - 99		
89	Reserved for Future Use			

TAX PROGRAMMING

Straight Tax Programming

Control Lock Position : PGM
Programming Step

- 1) Press [72] SUBTOTAL to enter the tax program procedure.
- 2) Enter the desired Tax Rate and status from the table below and press the X/TIME key.
Then push the CASH key.

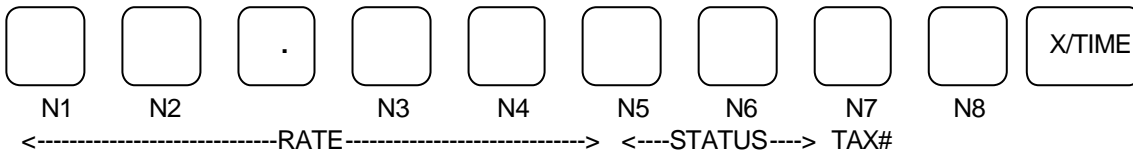

1 - 4

Addr.	Meaning	VALUE	=	SUM
N6	Tax is straight % / VAT	YES = 1		
	Tax is straight % / Add On	YES = 0	A	A
N7	GST (Tax 4) is Taxable by Rate 3	YES = 4 No = 0	A	A+B+C
	GST (Tax 4) is Taxable by Rate 2	YES = 2 No = 0	B	
	GST (Tax 4) is Taxable by Rate 1	YES = 1 No = 0	C	

Programming Example : (6.5% ON TAX 1)

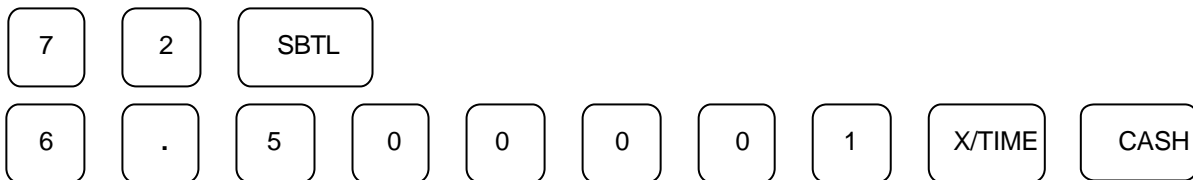

TABLE TAX RATE PROGRAMMING

Programming Information

- A) Maximum 60 tax breaks.
- B) Tax breaks determine at what dollar amount an additional .01 will be added to the tax total of the sale.
- C) Determine break points by subtracting the high side of a dollar range from the high side of the dollar range. (See example on the next page)
- D) The pattern of break points is the breaks pattern. (Repeat breaks repeat themselves)
- E) The beginning break points, that do not fit into the repeat breaks are the non-repeat breaks.

Programming steps

Control Lock Position : PGM

- 1) Press 72 SUBTOTAL to enter the tax program procedure.
- 2) Enter the desired table and press the X/TIME key.
- 3) Enter the correct tax number and then enter your table tax breaks according to your specific tax rate.

TABLE TAX RATE PROGRAMMING

Programming Example

Tax 1 is a 6.0% Illinois Table Tax

TAX CHARGED	SALE AMOUNT RANGE	BREAK POINT	
0.00	0.00 - 0.10		
0.01	0.11 - 0.21	11	Non - Repeat Breaks
0.02	0.22 - 0.38	17	
0.03	0.39 - 0.56	18	
0.04	0.57 - 0.73	17	
0.05	0.74 - 0.91	18	
0.06	0.92 - 1.08	17	Repeat Breaks
0.07	1.09 - 1.24	16	
0.08	1.25 - 1.41	17	Repeat Breaks
0.09	1.42 - 1.58	17	
0.10	1.59 - 1.74	16	
0.11	1.75 - 1.91	17	Repeat Breaks
0.12	1.92 - 2.08	17	
0.13	2.09 - 2.24	16	
0.14	2.25 - 2.41	17	

Enter 72 and Press SUBTOTAL key.	72	SUBTOTAL
Enter "1" for tax1 and Press X/TIME key.	1	X/TIME
Enter the maximum amount that is not taxed (0.10) and Press the X/TIME key.	10	X/TIME
Enter the first tax amount charged (0.01) and Press the X/TIME key.	1	X/TIME
Enter the high side of the dollar range for the first non-repeat break which charges tax (0.21) and Press the X/TIME key.	21	X/TIME
Repeat for each non-repeat break.	38	X/TIME,
	56	X/TIME,
	73	X/TIME
Enter "91" and Press the SUBTOTAL key.	91	SUBTOTAL
Enter the high side of the dollar range for the first repeat break in the repeat breaks pattern (1.08) and Press the X/TIME key.	108	X/TIME
Repeat for each repeat break.	124	X/TIME,
	141	X/TIME
Press CASH key to finalize.		CASH

CASH KEY PROGRAMMING

CASH key status programming

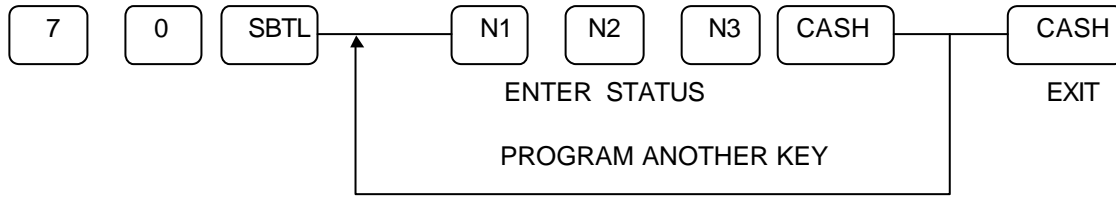

	KEY OPTION	VALUE	=	SUM
N1	EXEMPT TAX 1	YES = 1 / NO = 0	A	A+B+C
	EXEMPT TAX 2	YES = 2 / NO = 0	B	
	EXEMPT TAX 3	YES = 4 / NO = 0	C	
N2	EXEMPT TAX 4	YES = 1 / NO = 0	A	A+B+C
	CASH DRAWER DOES NOT OPEN	YES = 2 / NO = 0	B	
	VALIDATION COMPULSORY	YES = 4 / NO = 0	C	
N3	AMOUNT TENDER COMPULSORY	YES = 1 / NO = 0	A	A+B+C
	DISABLE UNDER-TENDERING	YES = 2 / NO = 0	B	
	DISABLE HALO IN X-MODE	YES = 4 / NO = 0	C	

CASH key descriptor programming

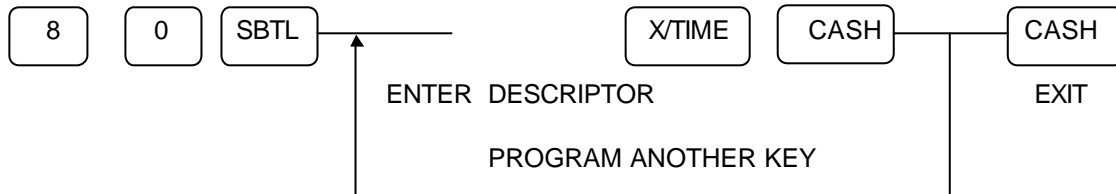

CASH key amount programming

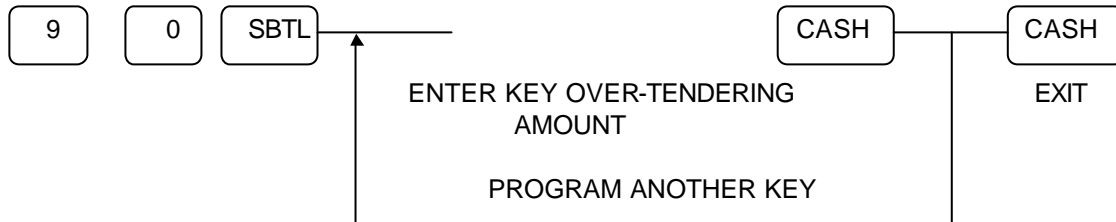

CHEQUE KEY PROGRAMMING

CHEQUE key status programming

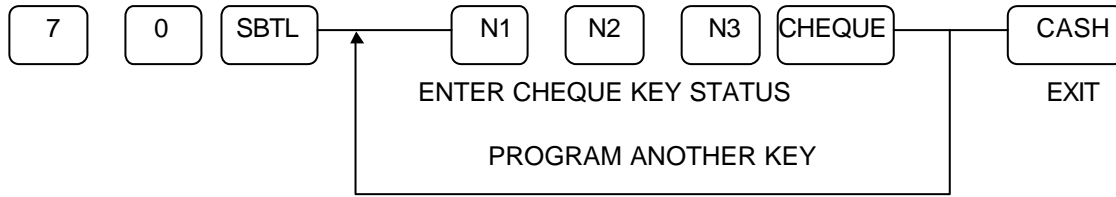

	KEY OPTION	VALUE	=	SUM
N1	EXEMPT TAX 1	YES = 1 / NO = 0	A	A+B+C
	EXEMPT TAX 2	YES = 2 / NO = 0	B	
	EXEMPT TAX 3	YES = 4 / NO = 0	C	
N2	EXEMPT TAX 4	YES = 1 / NO = 0	A	A+B+C
	CASH DRAWER DOES NOT OPEN VALIDATION IS COMPULSORY	YES = 2 / NO = 0	B	
		YES = 4 / NO = 0	C	
N3	AMOUNT TENDER COMPULSORY	YES = 1 / NO = 0	A	A+B+C
	DISABLE UNDER-TENDERING	YES = 2 / NO = 0	B	
	DISABLE HALO IN X-MODE	YES = 4 / NO = 0	C	
N4	PLEASE NOTE: IN THE CASE OF 4MEG EPROMS (ONLY) ENTER '0' HERE TO MAKE A 4 DIGIT STATUS FIELD	0	0	0

CHEQUE key descriptor programming

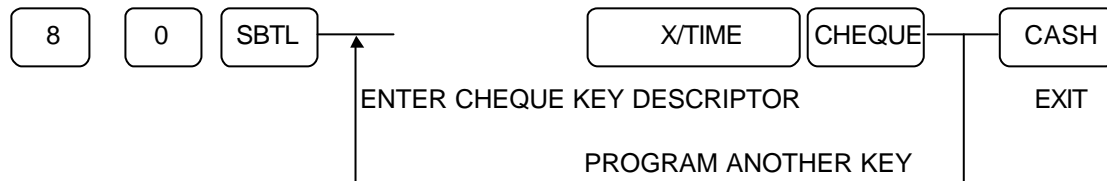

CHEQUE key amount programming

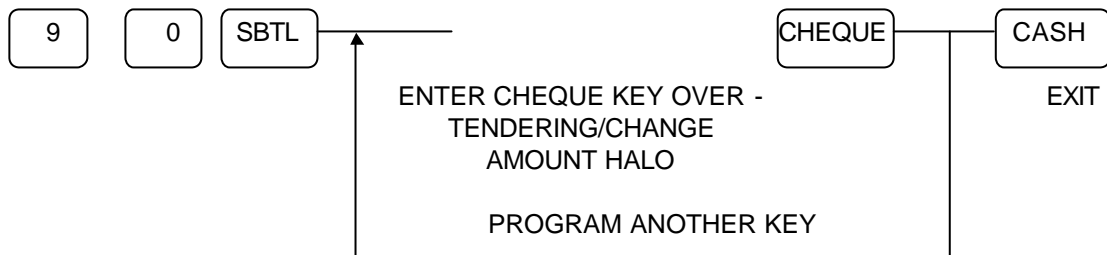

CHARGE KEY PROGRAMMING

CHARGE key status programming

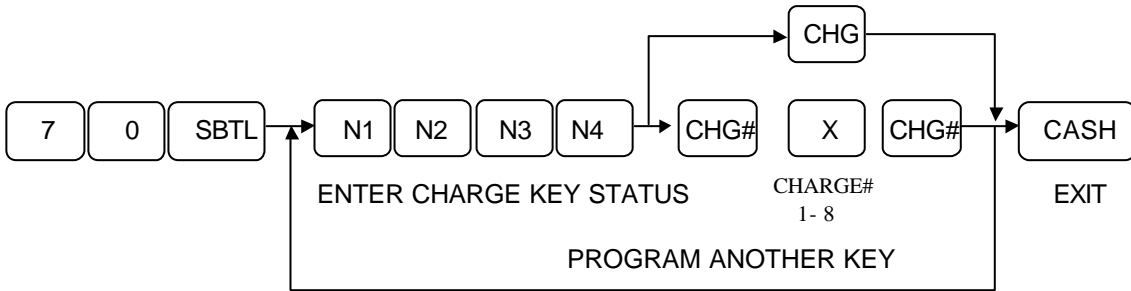

	KEY OPTION	VALUE	=	SUM
N1	EXEMPT TAX 1	YES = 1 / NO = 0	A	A+B+C
	EXEMPT TAX 2	YES = 2 / NO = 0	B	
	EXEMPT TAX 3	YES = 4 / NO = 0	C	
N2	EXEMPT TAX 4	YES = 1 / NO = 0	A	A+B+C
	CASH DRAWER DOES NOT OPEN VALIDATION IS COMPULSORY	YES = 2 / NO = 0	B	
		YES = 4 / NO = 0	C	
N3	AMOUNT TENDER COMPULSORY	YES = 1 / NO = 0	A	A+B+C
	DISABLE UNDER-TENDERING	YES = 2 / NO = 0	B	
	UNDER TENDERING IN X-MODE	YES = 4 / NO = 0	C	
N4	NON-ADD # ENTRY COMPULSORY	YES = 1 / NO = 0	A	A+B
	ENABLE CHARGE OVER-TENDERING	YES = 2 / NO = 0	B	

CHARGE key descriptor programming

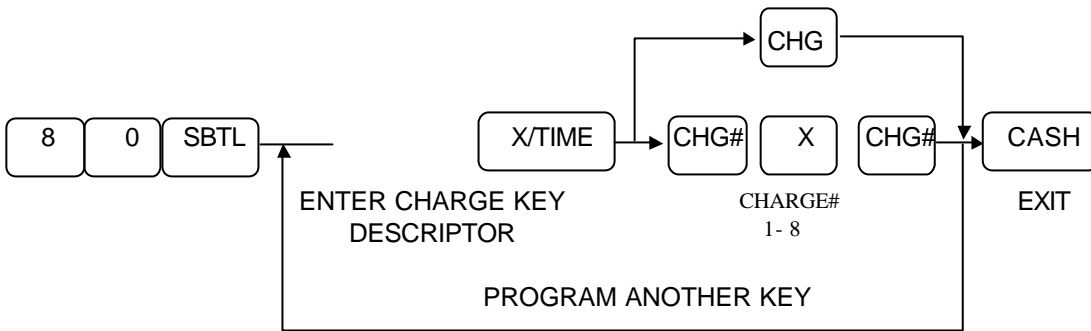

CURRENCY KEY PROGRAMMING

CURRENCY key status programming

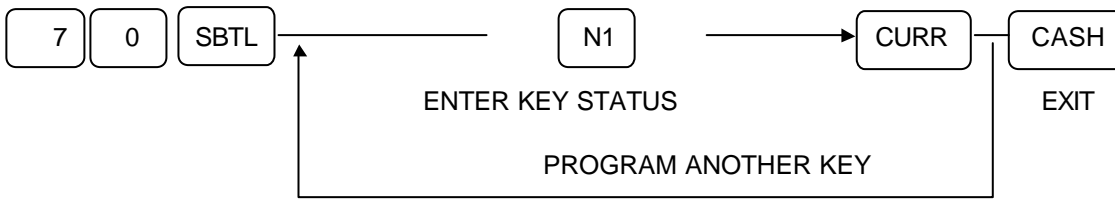

	KEY OPTION	VALUE	=	SUM
N1	LINKED DRAWER NO.	0 ~ 3		

CURRENCY key descriptor programming

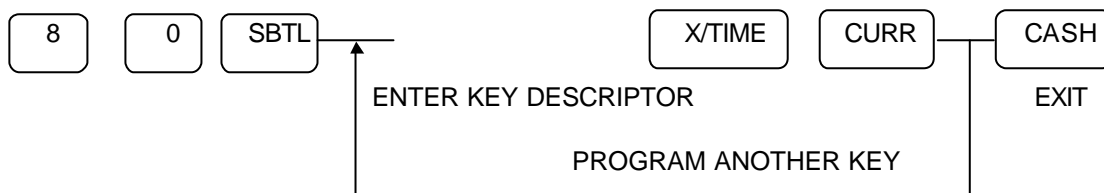

CURRENCY key amount programming

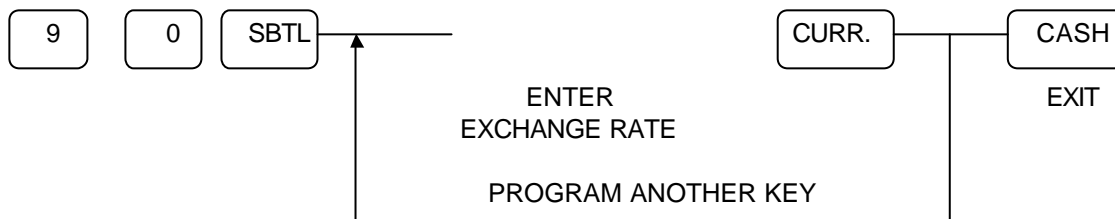

* In the exchange rate, the last digit is used to designate the decimal position.
 For example, 12003 at program is rate for 1.200 and 12002 at program is rate for 12.00.

% KEY PROGRAMMING

% key status programming

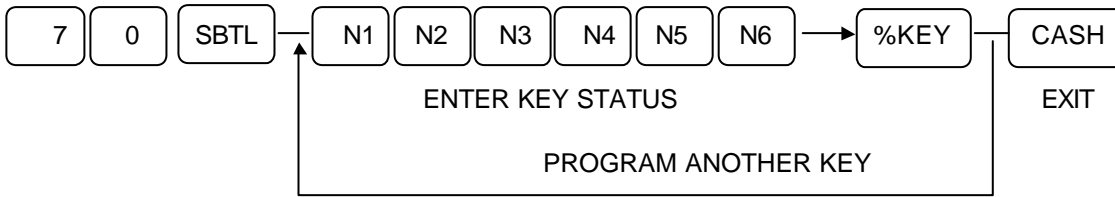

	KEY OPTION	VALUE	=	SUM
N1	ALLOW % KEY PRESET OVERRIDE PRESET OVERRIDE IN X-MODE ONLY % KEY ACTIVE IN X-MODE ONLY	YES = 1 / NO = 0 YES = 2 / NO = 0 YES = 4 / NO = 0	A B C	A+B+C
N2	% KEY IS % KEY IS % KEY IS	SALE = 1 / ITEM = 0 AMOUNT = 2 / PERCENTAGE = 0 INACTIVE = 4 / ACTIVE = 0	A B C	A+B+C
N3	TAXABLE BY TAX 1 TAXABLE BY TAX 2 TAXABLE BY TAX 3	YES = 1 / NO = 0 YES = 2 / NO = 0 YES = 4 / NO = 0	A B C	A+B+C
N4	TAXABLE BY TAX 4 % KEY IS % KEY IS	YES = 1 / NO = 0 POSITIVE = 2 / NEGATIVE = 0 OPEN = 4 / PRESET = 0	A B C	A+B+C
N5	% KEY NETS TOTAL % KEY REQUIRE VALIDATION	YES = 1 / NO = 0 YES = 2 / NO = 0	A B	A+B
N6	ALLOW AMOUNT COUPONS WITHOUT PUSHING SUBTOTAL ** ALLOW ONLY ONE SUB,DISCOUNT	YES = 1 / NO = 0 YES = 2 / NO = 0	A B	A+B

** Set the N2-A and N2-B to set this option.

% KEY PROGRAMMING

% key descriptor programming



% key amount programming

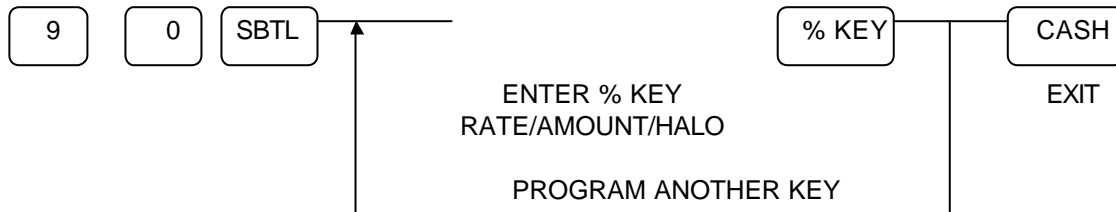

Number of decimal places is 3 if the key option(N2) is set to PERCENTAGE 2. If the key option(N2) is set to AMOUNT the number of decimal places is 2.

ERR CORR KEY PROGRAMMING

ERR CORR key status programming

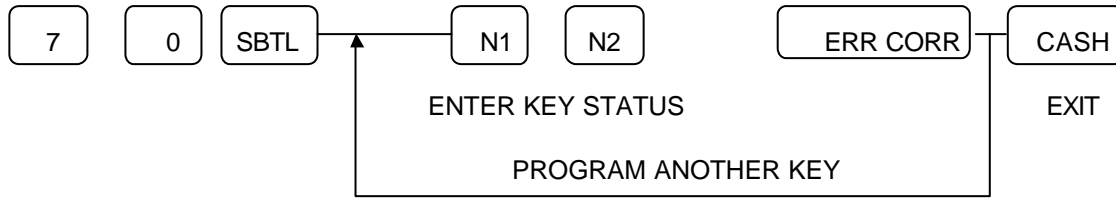

	KEY OPTION	VALUE	=	SUM
N1	KEY IS INACTIVE	YES = 1 / NO = 0	A	A+B+C
	KEY IS ACTIVE IN X-MODE ONLY	YES = 2 / NO = 0	B	
	VALIDATION COMPULSORY	YES = 4 / NO = 0	C	
N2	INHIBIT PRINTING ON REPORT	YES = 1 / NO = 0	A	A

ERR CORR key descriptor programming



ERR CORR key amount programming

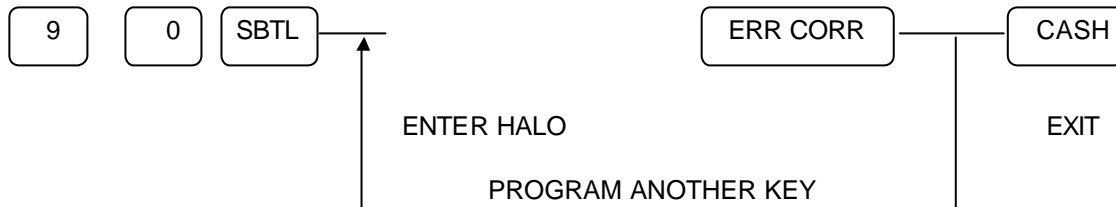

VOID KEY PROGRAMMING

VOID key status programming

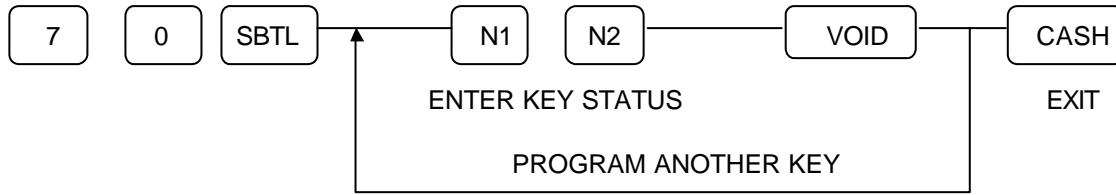

	KEY OPTION	VALUE	=	SUM
N1	KEY IS INACTIVE	YES = 1 / NO = 0	A	A+B+C
	KEY IS ACTIVE IN X-MODE ONLY	YES = 2 / NO = 0	B	
	VALIDATION COMPULSORY	YES = 4 / NO = 0	C	
N2	INHIBIT PRINTING ON REPORT	YES = 1 / NO = 0	A	A

VOID key descriptor programming



VOID key amount programming

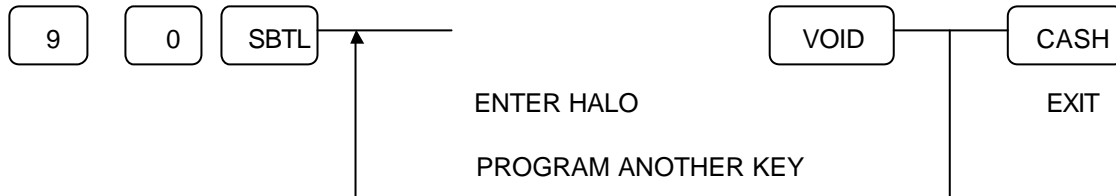

PROMO KEY PROGRAMMING

PROMO key status programming

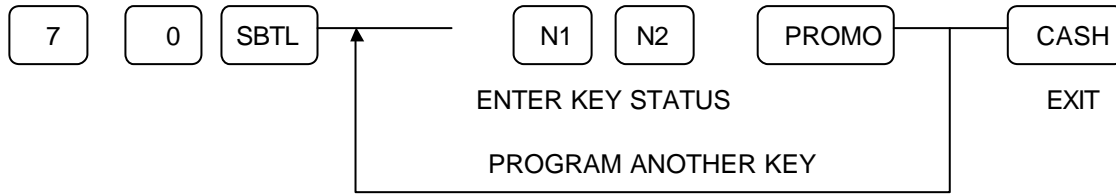

	KEY OPTION	VALUE	=	SUM
N1	KEY IS INACTIVE	YES = 1 / NO = 0	A	A+B+C
	KEY IS ACTIVE IN X-MODE ONLY	YES = 2 / NO = 0	B	
	TAXABLE BY TAX1	YES = 4 / NO = 0	C	
N2	TAXABLE BY TAX2	YES = 1 / NO = 0	A	A+B+C
	TAXABLE BY TAX3	YES = 2 / NO = 0	B	
	TAXABLE BY TAX4	YES = 4 / NO = 0	C	

PROMO key descriptor programming



WASTE KEY PROGRAMMING

WASTE key status programming



	KEY OPTION	VALUE	=	SUM
N1	KEY IS INACTIVE	YES = 1 / NO = 0	A	A+B+C
	KEY IS ACTIVE IN X-MODE ONLY	YES = 2 / NO = 0	B	
	VALIDATION COMPULSORY	YES = 4 / NO = 0	C	

WASTE key descriptor programming

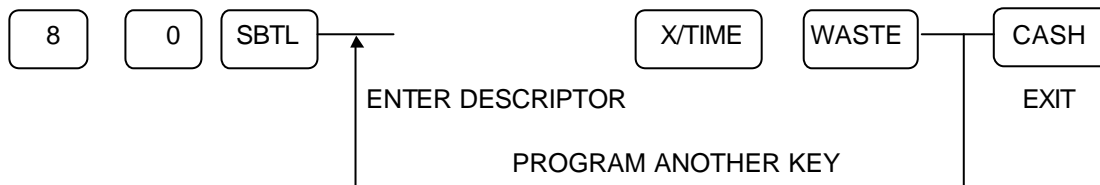

CANCEL KEY PROGRAMMING

CANCEL key status programming

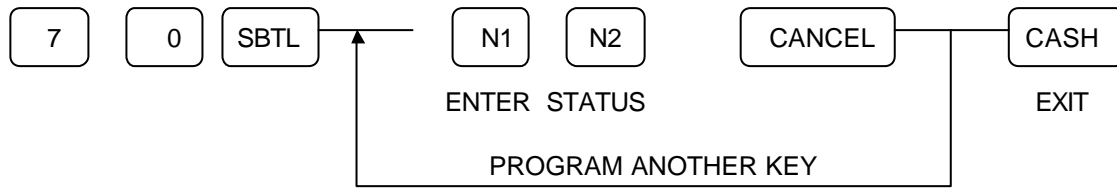

	KEY OPTION	VALUE	=	SUM
N1	CANCEL INACTIVE	YES = 1 / NO = 0	A	A+B+C
	CANCEL ACTIVE IN X-MODE ONLY	YES = 2 / NO = 0	B	
	VALIDATION COMPULSORY ON CANCEL	YES = 4 / NO = 0	C	
N2	INHIBIT PRINTING ON REPORTS	YES = 1 / NO = 0	A	A

CANCEL key descriptor programming

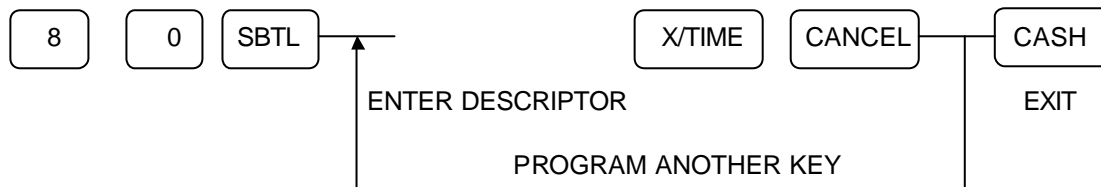

CANCEL key amount programming

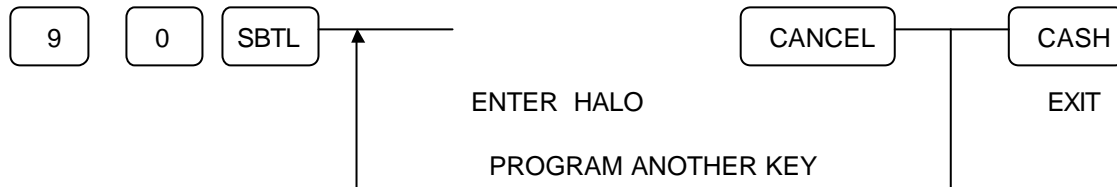

PAID OUT KEY PROGRAMMING

Paid Out key status programming



	KEY OPTION	VALUE	=	SUM
N1	P/O INACTIVE	YES = 1 / NO = 0	A	A+B+C
	P/O ACTIVE IN X-MODE ONLY	YES = 2 / NO = 0	B	
	VALIDATION COMPULSORY ON P/O	YES = 4 / NO = 0	C	

Paid Out key descriptor programming

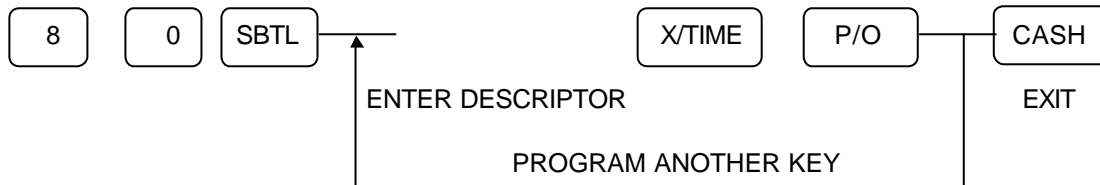

Paid Out key amount programming

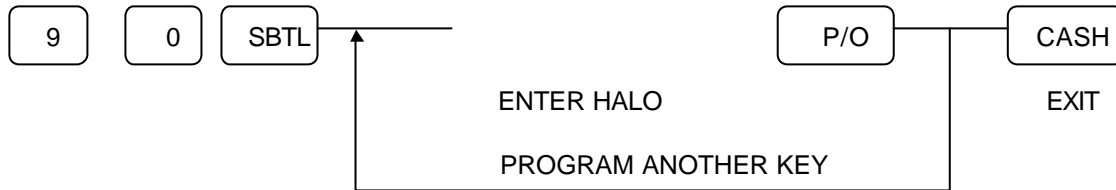

RECEIVED ON ACCOUNT KEY PROGRAMMING

Received on Account key status programming



	KEY OPTION	VALUE	=	SUM
N1	R/A INACTIVE	YES = 1 / NO = 0	A	A+B+C
	R/A ACTIVE IN X-MODE ONLY	YES = 2 / NO = 0	B	
	VALIDATION COMPULSORY ON R/A	YES = 4 / NO = 0	C	

Received on Account key descriptor programming

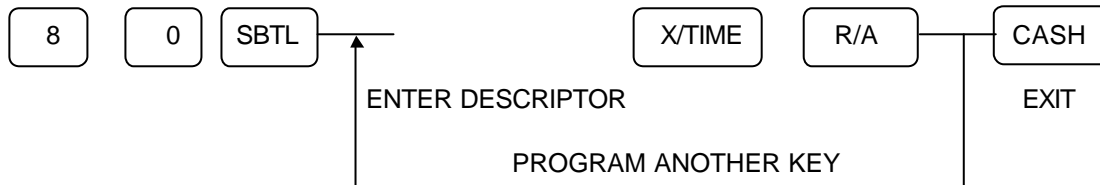

Received on Account key amount programming

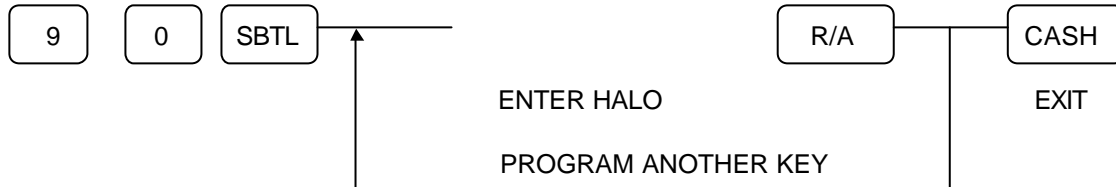

RETURN KEY PROGRAMMING

RETURN key status programming



	KEY OPTION	VALUE	=	SUM
N1	RETURN INACTIVE	YES = 1 / NO = 0	A	A+B+C
	RETURN ACTIVE IN X-MODE ONLY	YES = 2 / NO = 0	B	
	VALIDATION COMPULSORY ON RETURN	YES = 4 / NO = 0	C	
N2	DOES NOT ADD TO GRAND TOTALS	YES = 1 / NO = 0	A	A+B+C
	INHIBIT PRINTING ON REPORTS	YES = 2 / NO = 0	B	
	DOES NOT ADD TO PLU TOTAL	YES = 4 / NO = 0	C	

RETURN key descriptor programming



RETURN key amount programming

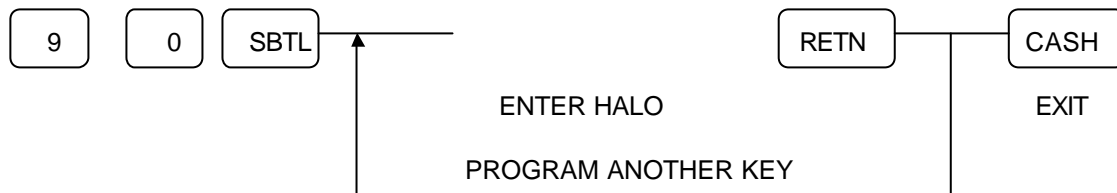

TAX EXEMPT KEY PROGRAMMING

TAX EXEMPT key status programming



	KEY OPTION	VALUE	=	SUM
N1	EXEMPT TAX 1	YES = 1 / NO = 0	A	A+B+C
	EXEMPT TAX 2	YES = 2 / NO = 0	B	
	EXEMPT TAX 3	YES = 4 / NO = 0	C	
N2	EXEMPT TAX 4	YES = 1 / NO = 0	A	A+B+C
	NON-ADD # ENTRY COMPULSORY	YES = 2 / NO = 0	B	
	COMPULSORY VALIDATION	YES = 4 / NO = 0	C	

TAX EXEMPT key descriptor programming

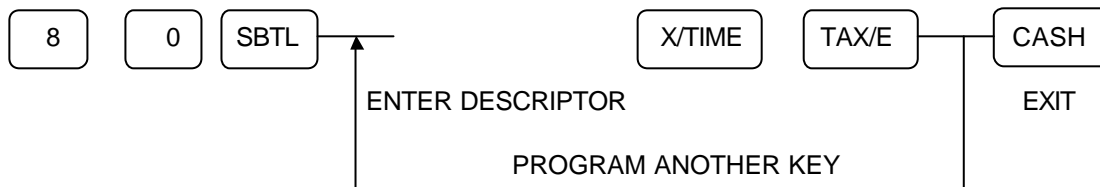

EAT-IN/TAKE-OUT/DRIVE-THU KEY PROGRAMMING

EAT-IN/TAKE-OUT/DRIVE-THROUGH key status programming

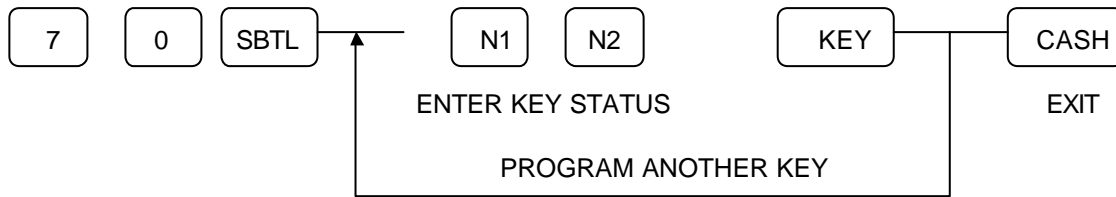

	KEY OPTION	VALUE	=	SUM
N1	EXEMPT TAX 1	YES = 1 / NO = 0	A	A+B+C
	EXEMPT TAX 2	YES = 2 / NO = 0	B	
	EXEMPT TAX 3	YES = 4 / NO = 0	C	
N2	EXEMPT TAX 4	YES = 1 / NO = 0	A	A+B
	VALIDATION COMPULSORY	YES = 2 / NO = 0	B	

EAT-IN/TAKE-OUT/DRIVE-THROUGH key descriptor programming

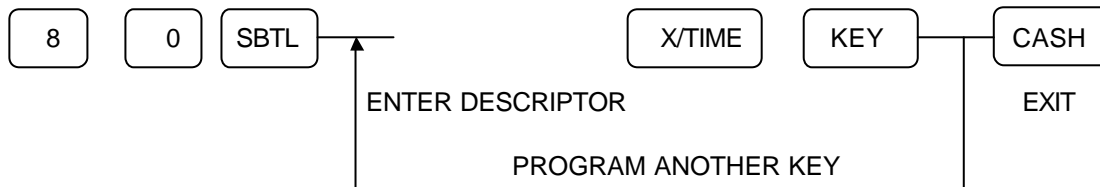

PRINT KEY PROGRAMMING ⁰⁰

PRINT key output programming

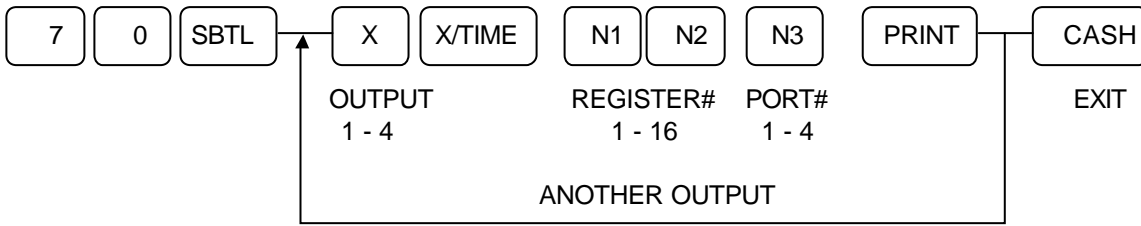

PRINT key backup output programming

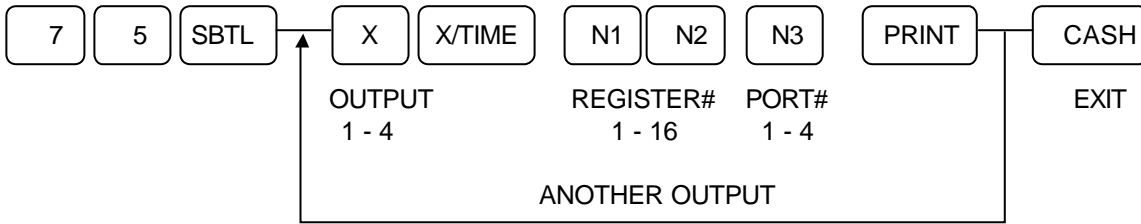

PRINT key descriptor programming



NO SALE KEY PROGRAMMING

NO SALE key status programming

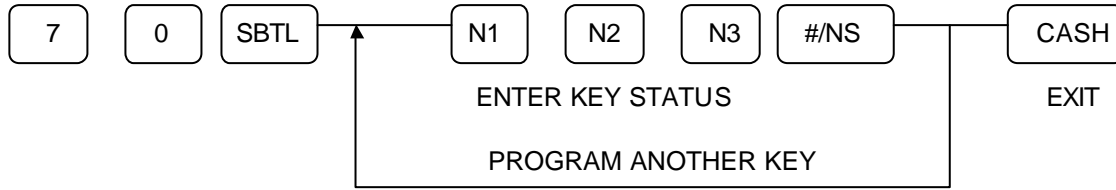

	KEY OPTION	VALUE	=	SUM
N1	NO SALE INACTIVE*	YES = 1 / NO = 0	A	A+B+C
	NO SALE ACTIVE IN XMODE ONLY	YES = 2 / NO = 0	B	
	VALIDATION COMPULSORY ON NO SALE	YES = 4 / NO = 0	C	
N2	NO SALE INACTIVE AFTER # ENTRY	YES = 1 / NO = 0	A	A+B+C
	ENFORCE # ENTRY AT START OF SALE	YES = 2 / NO = 0	B	
	NON-ADD ENTRIES ARE INHIBITED	YES = 4 / NO = 0	C	
N3	COMPULSORY DIGIT ENTRY MUST BE	YES = 1 / NO = 0	A	A+B
	NUMBER OF DIGITS OF THE DIGIT HALO		B	

* The non-add # entry will still function even if the no sale key is programmed as inactive

NO SALE key descriptor programming

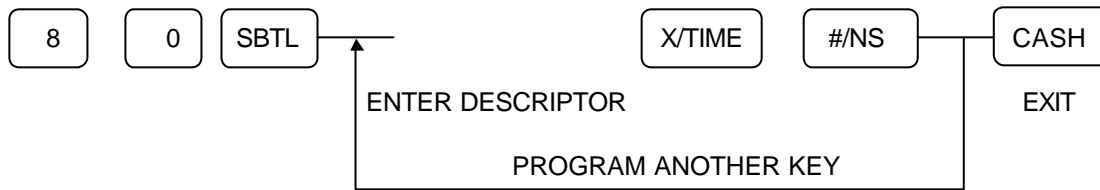

NO SALE key digit entry programming

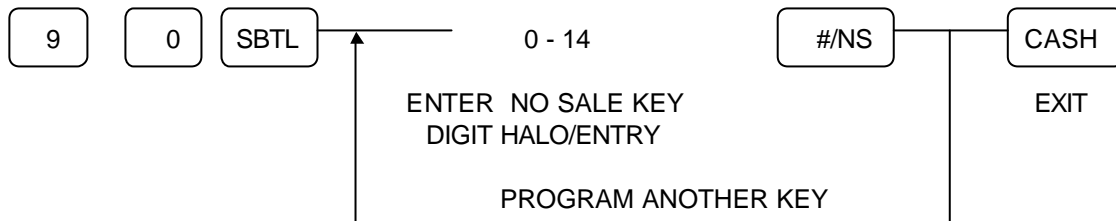

CHECK CASHING KEY PROGRAMMING

CHECK CASHING key status programming



	KEY OPTION	VALUE	=	SUM
N1	CHECK CASHING INACTIVE	YES = 1 / NO = 0	A	A+B+C
	CHECK CASHING IN XMODE ONLY	YES = 2 / NO = 0	B	
	HALO OVERRIDE IN XMODE	YES = 4 / NO = 0	C	
N2	VALIDATION COMPULSORY	YES = 1 / NO = 0	A	A

CHECK CASHING key descriptor programming

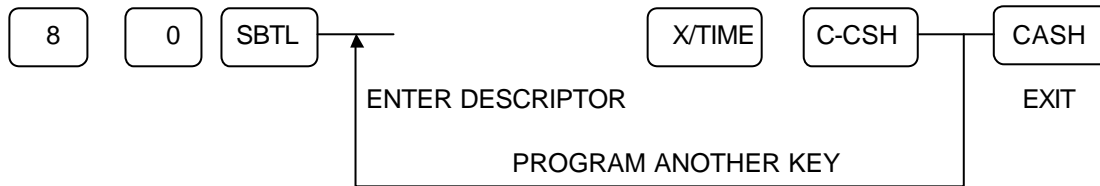

CHECK CASHING key amount programming

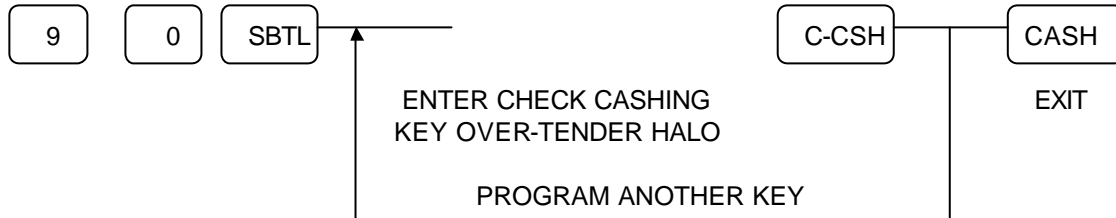

TIME IN/OUT KEY PROGRAMMING

TIME IN/OUT key status programming



	KEY OPTION	VALUE	=	SUM
N1	KEY IS INACTIVE	YES = 1 / NO = 0	A	A+B+C
	KEY IS ACTIVE IN X-MODE ONLY	YES = 2 / NO = 0	B	
	VALIDATION COMPULSORY	YES = 4 / NO = 0	C	

TIME IN/OUT key descriptor programming

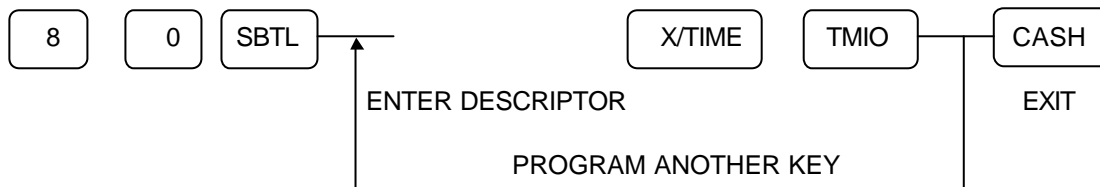

P/BAL KEY PROGRAMMING

P/BAL key status programming



	KEY OPTION	VALUE	=	SUM
N1	P/BAL MUST BE ENTERED AT START OF SALE	YES = 1 / NO = 0	A	A+B+C
	P/BAL CAN BE ENTERED AT ANY TIME	YES = 2 / NO = 0	B	
	P/BAL USED FOR DRIVE-THROUGH	YES = 4 / NO = 0	C	

P/BAL key descriptor programming

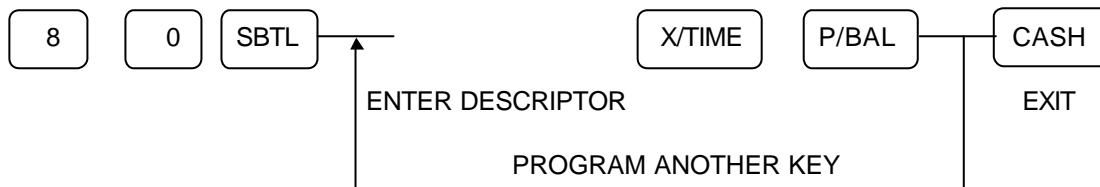

CHECK # KEY PROGRAMMING

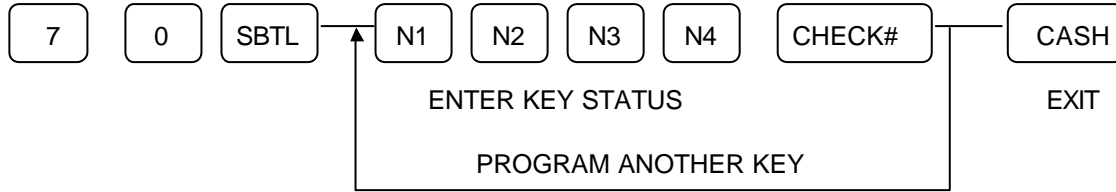

	KEY OPTION	VALUE	=	SUM
N1	CHECK # IS COMPULSORY FOR ALL SALES	YES = 1 / NO = 0	A	A+B+C
	CHECK # IS ASSIGNED BY THE REGISTERS	YES = 2 / NO = 0	B	
	OPEN CHECKS ARE ONLY AVAILABLE TO THE CLERK WHO OPENED THOSE	YES = 4 / NO = 0	C	
N2	CHECK # DOES NOT PRINT ON RECEIPT	YES = 1 / NO = 0	A	A+B+C
	CHECK # DOES NOT PRINT ON DETAIL	YES = 2 / NO = 0	B	
	PRINT CHECK # ON K/P ⁰⁰	YES = 4 / NO = 0	C	
N3	CHECK TRACK FEATURE IS DRIVE THRU*	YES = 1 / NO = 0	A	A+B+C
	PRINT POST AMBLE	YES = 2 / NO = 0	B	
	PRINT PRE AMBLE	YES = 4 / NO = 0	C	
N4	ALLOW ONLY ONE CHECK PER TABLE	YES = 1 / NO = 0	A	A
	Enable NEW CHECK feature (V1.55)	YES = 2 / NO = 0		
N5	MAXIMUM LENGTH OF CHECK#	1 - 7		

* Register will automatically recall the lowest # in the system when check # key is pushed.

CHECK # key descriptor programming



CHECK # key starting check # programming

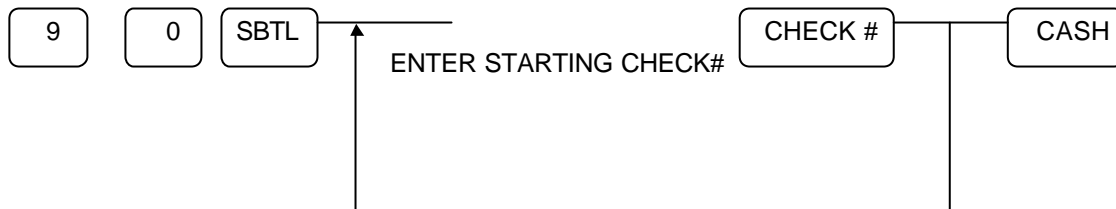

TABLE # KEY PROGRAMMING

TABLE # key status programming



	KEY OPTION	VALUE	=	SUM
N1	TABLE # COMPULSORY FOR CHECK # / P/BAL	YES = 1 / NO = 0	A	
	TABLE # COMPULSORY FOR ALL SALES	YES = 2 / NO = 0	B	A+B+C
	PRINT TABLE # ON K/P ⁰⁰	YES = 4 / NO = 0	C	

TABLE # key descriptor programming



GUEST # KEY PROGRAMMING

GUEST # key status programming



	KEY OPTION	VALUE	=	SUM
N1	GUEST # COMPULSORY FOR CHECK # or P/BAL	YES = 1 / NO = 0	A	A+B+C
	GUEST # COMPULSORY FOR ALL SALES	YES = 2 / NO = 0	B	
	PRINT GUEST # ON K/P ⁰⁰	YES = 4 / NO = 0	C	

GUEST # key descriptor programming



SERVICE KEY PROGRAMMING

SERVICE key status programming

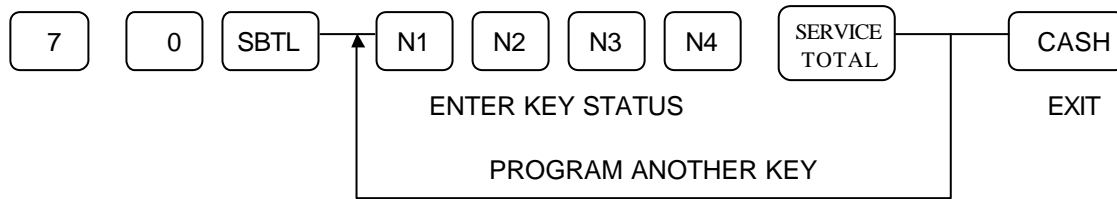

	KEY OPTION	VALUE	=	SUM
N1	VALIDATION IS COMPULSORY NON-ADD NUMBER IS COMPULSORY DOES NOT PRINT ON RECEIPT	YES = 1 / NO = 0 YES = 2 / NO = 0 YES = 4 / NO = 0	A B C	A+B+C
N2	DOES NOT PRINT ON DETAIL NEGATIVE TOTAL IN X-MODE ONLY DO NOT PRINT TAX DETAILS UNTIL FINALISING THE CHECK	YES = 1 / NO = 0 YES = 2 / NO = 0 YES = 4 / NO = 0	A B C	A+B+C
N3	<i>Future use</i>			
N4	HARD CHECK AND P/BAL COMM. PORT#	0 - 4		

SERVICE key descriptor programming



PRINT CHECK / SLIP PRINT KEY PROGRAMMING

PRINT CHECK key status programming

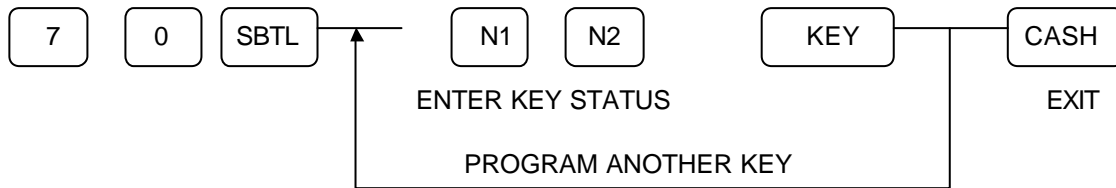

	KEY OPTION	VALUE	=	SUM
N1	CHECK PRINTS ON COM PORT#	0 - 4		
N2	WILL AUTOMATICALLY SERVICE CHECK OUT	YES = 1 / NO = 0	A	A+B+C
	PRINT ON RECEIPT	YES = 2 / NO = 0	B	
	DOES NOT PRINT CONSECUTIVE NO.	YES = 4 / NO = 0	C	

PRINT CHECK key descriptor programming

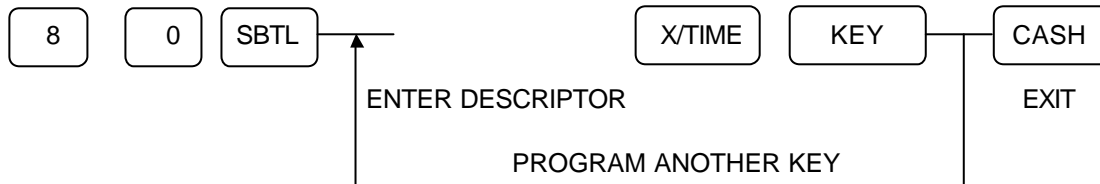

TIP KEY PROGRAMMING

TIP key status programming

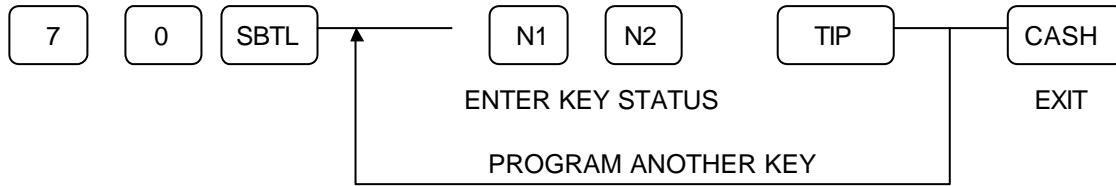

	KEY OPTION	VALUE	=	SUM
N1	TIP KEY TYPE IS	AMOUNT = 0 / PERCENTAGE = 1	A	A+B+C
	TAXABLE BY TAX1	YES = 2 / NO = 0	B	
	TAXABLE BY TAX2	YES = 4 / NO = 0	C	
N2	TAXABLE BY TAX3	YES = 1 / NO = 0	A	A+B+C
	TAXABLE BY TAX4	YES = 2 / NO = 0	B	
	ADD TO NET / GROSS TOTAL	YES = 4 / NO = 0	C	

TIP key descriptor programming



MACRO KEY PROGRAMMING

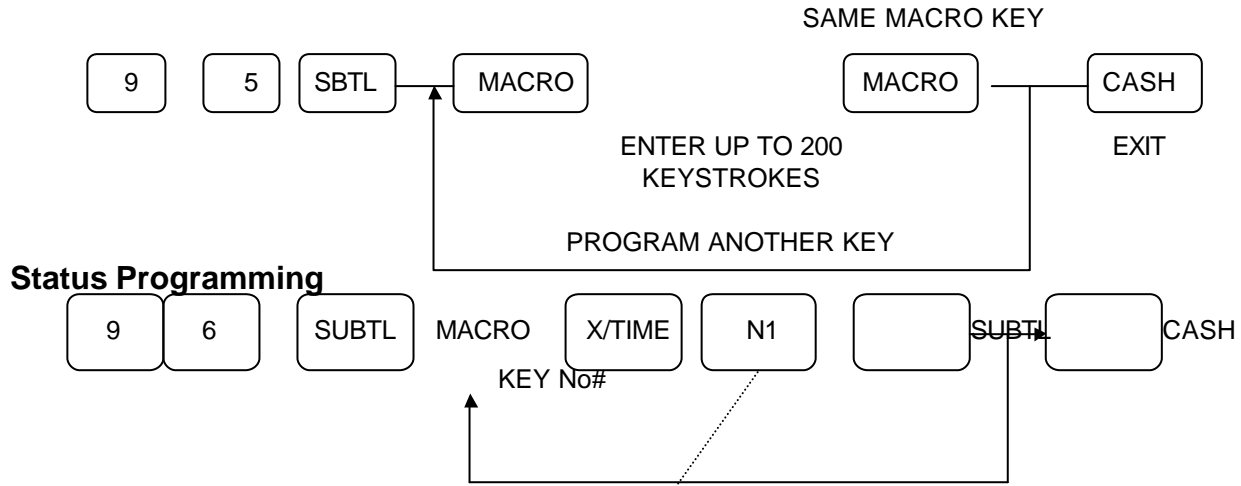

Active in REG/ VOID Only	A =	
	4	
Active in X/Z Only	B =	A+B+
	2	C
Active in PGM ONLY	C =	
	1	

ADD, DEDUCT & STOCK OVERWRITE KEYS

Key Status programming

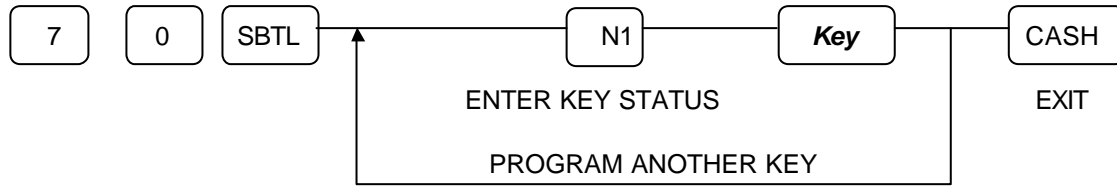

If no status is programmed then these functions are available in both X and Z mode.

N1	Inactive	A = 1	A+B
	Active in Program Only	B = 2	

PLU PROGRAMMING

PLU access method 1:-

PLU Level input in P-Mode

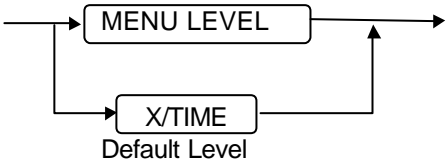

PLU access method 2:-

PLU Entry for Direct PLU in P-Mode

Using PLU# key

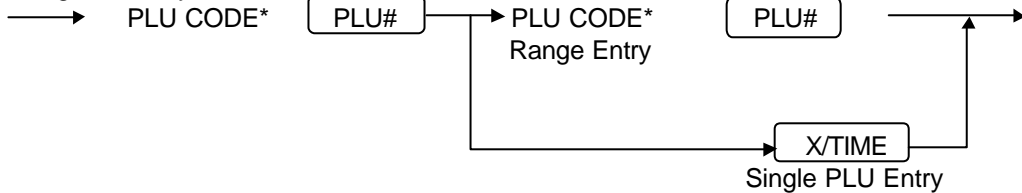

* 6 digits for SER6500, 18 digits for SER6540.

Using PLU key on the keyboard

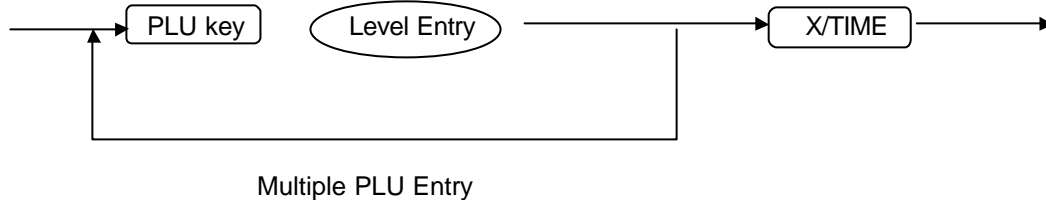

PLU access method 3:-

PLU Entry for Batch PLU in P-Mode

Using PLU# key



Using PLU key on the keyboard



PLU PROGRAMMING

PLU Programming (All Parts)

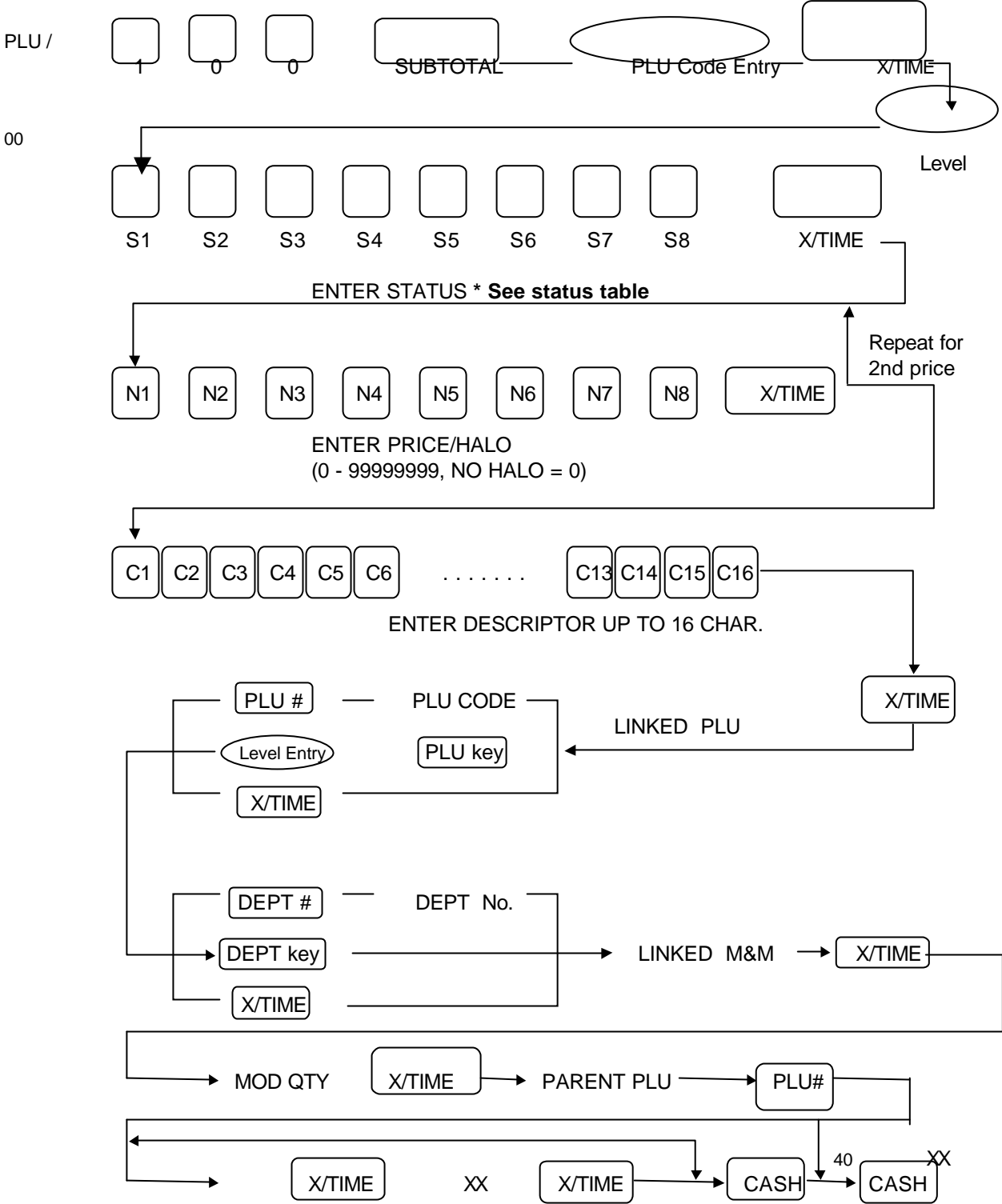

PLU PROGRAMMING

PLU Status options

Addr.	PLU Status	VALUE	=	SUM
1	PLU is Taxable by Rate 1	YES = 1 / NO = 0	A	A+B+C
	PLU is Taxable by Rate 2	YES = 2 / NO = 0	B	
	PLU is Taxable by Rate 3	YES = 4 / NO = 0	C	
2	PLU is Taxable by Rate 4	YES = 1 / NO = 0	A	A+B+C
	PLU is Not Discountable	YES = 2 / NO = 0	B	
	PLU is a Condiment ⁰⁰	YES = 4 / NO = 0	C	
3	PLU is Negative	YES = 1 / NO = 0	A	A+B+C
	PLU is Single Item	YES = 2 / NO = 0	B	
	PLU is HASH PLU	YES = 4 / NO = 0	C	
4	PLU is Gallonage PLU *	YES = 1 / NO = 0	A	A+B+C
	Enable PLU Price Change	YES = 2 / NO = 0	B	
	Enable Zero Price PLU Sale	YES = 4 / NO = 0	C	
5	Compulsory Non - Add Entry	YES = 1 / NO = 0	A	A+B+C
	Compulsory Validation	YES = 2 / NO = 0	B	
	Compulsory Condiment Entry ⁰⁰	YES = 4 / NO = 0	C	
6	PLU does not Print on Receipt	YES = 1 / NO = 0	A	A+B+C
	PLU does not Print on Detail	YES = 2 / NO = 0	B	
	PLU Prints Red on Kitchen Printer ⁰⁰	YES = 4 / NO = 0	C	
7	Allow Preset Override	YES = 2 / NO = 0	A	A+B+C
	PLU Prints on Kitchen Printer ⁰⁰	YES = 1 / NO = 0	B	
	Scaleable PLU	YES = 4 / NO = 0	C	
8	PLU is Preset	YES = 0	A	A+B
	PLU is Open	YES = 1		
	PLU is Disabled	YES = 2		
	Disable PROMO on this PLU	YES = 4 / NO = 0	B	

* If this is set, the PLU HALO has 3 digits under the decimal point.

PLU PROGRAMMING

PLU Deletion



* PLU which has amount or count in Z1, Z2 or Z3 report can not be deleted.

PLU Status Programming

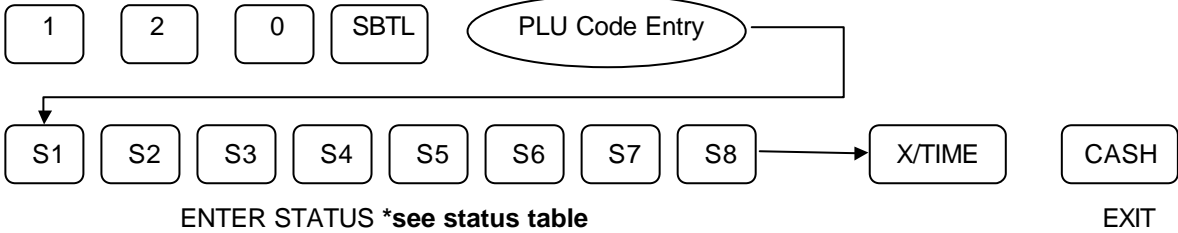

PLU PRICE/HALO Programming

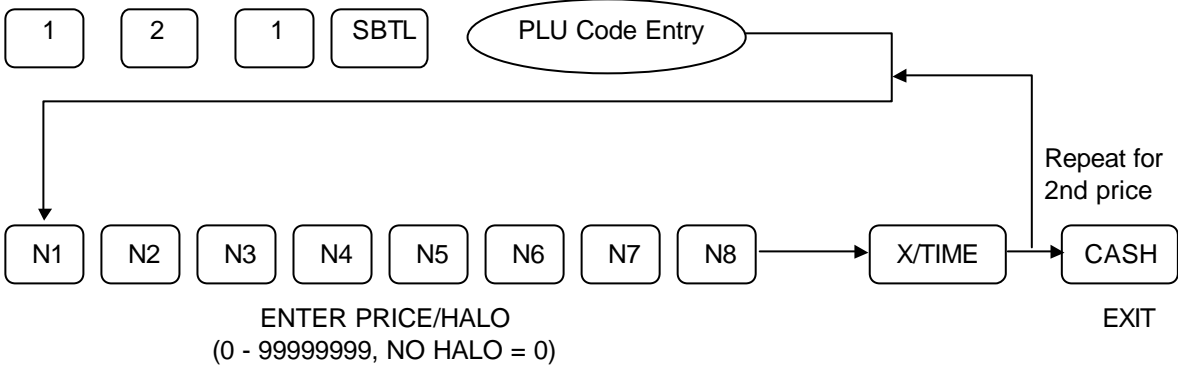

PLU Descriptor Programming

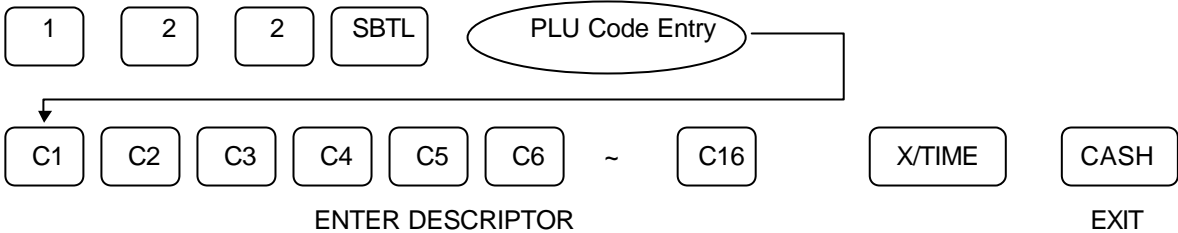

Note:- The first twelve characters are printed in a larger font on an external printer as the kitchen descriptor

PLU PROGRAMMING

PLU Link PLU Programming

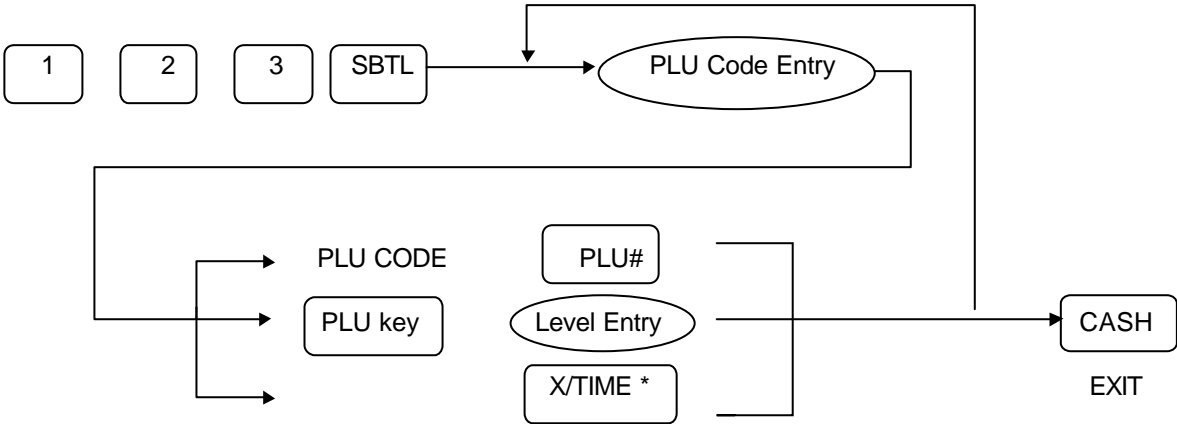

* Pressing X/TIME other than "PLU#" or "PLU key" will link nothing.

PLU Link Department Programming

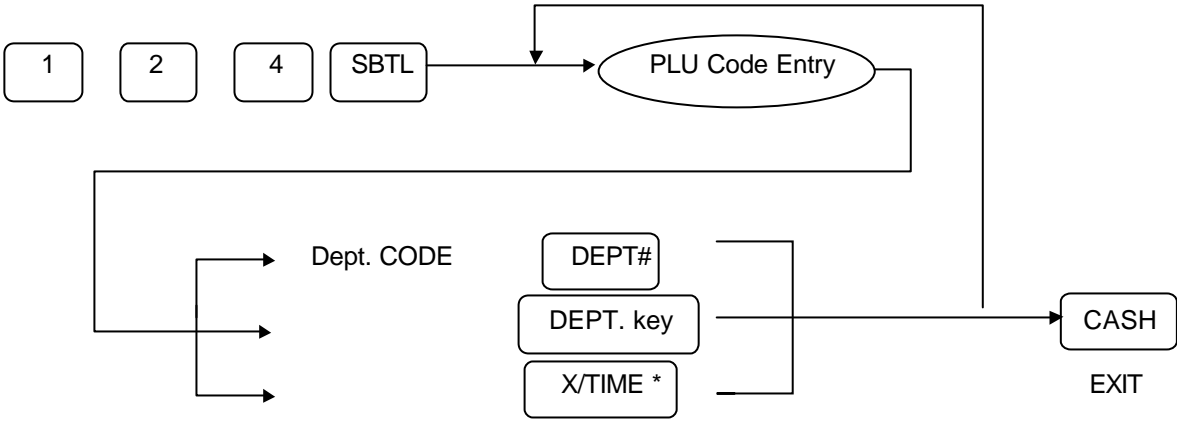

* Pressing X/TIME other than "PLU#" or "PLU key" will link nothing.

PLU PROGRAMMING

PLU Mix & Match Table Link Programming

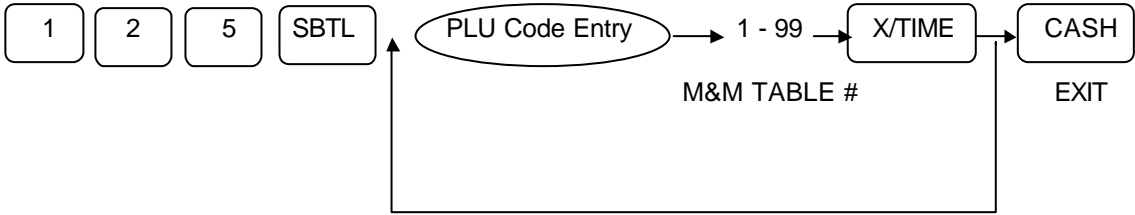

PLU Kitchen Printer Programming⁰⁰

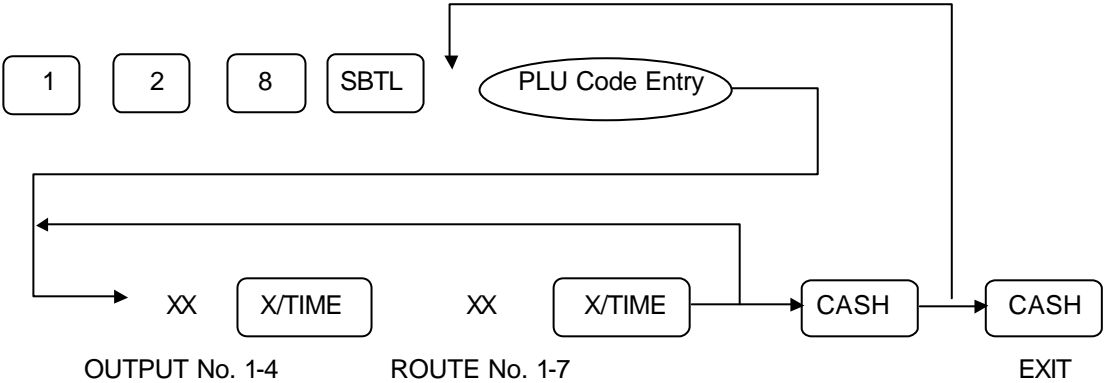

PLU Quantity Modifier Programming

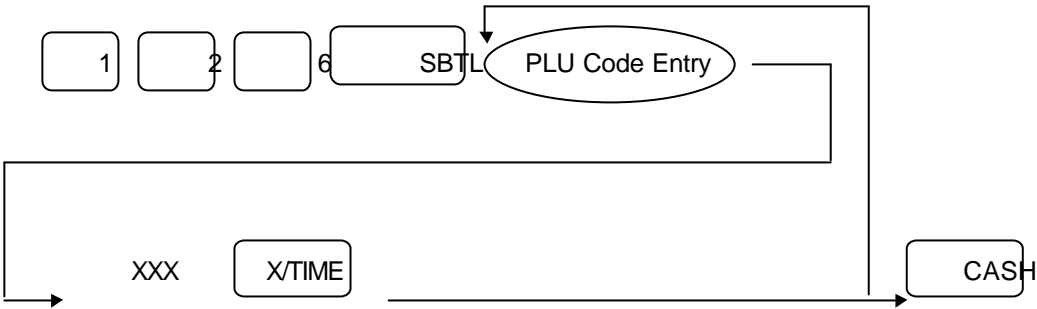

Modifier Quantity

Assumes 2 decimal places

PLU PROGRAMMING

PLU Stock Link

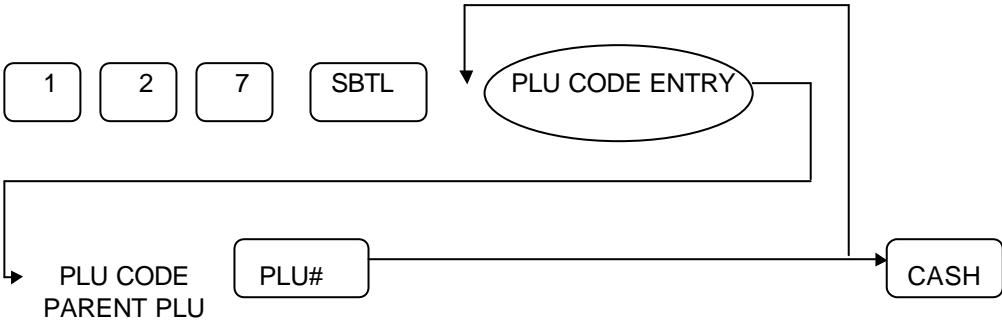

This feature links a PLU to a Parent PLU for the purpose of controlling stock. If the child PLU is sold the stock from the parent PLU is deducted dependant on the Quantity modifier.

Direct PLU Minimum Stock Level Programming

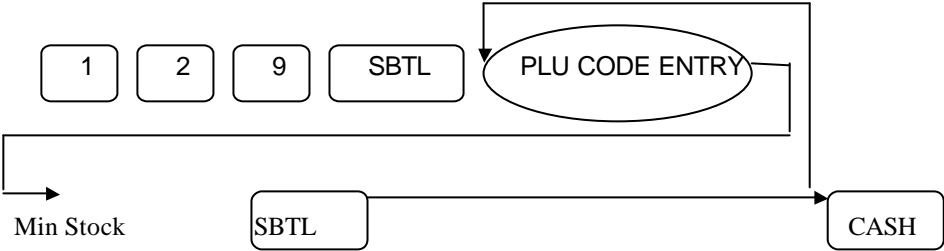

PLU PROGRAMMING

Batch PLU Programming (All Parts)

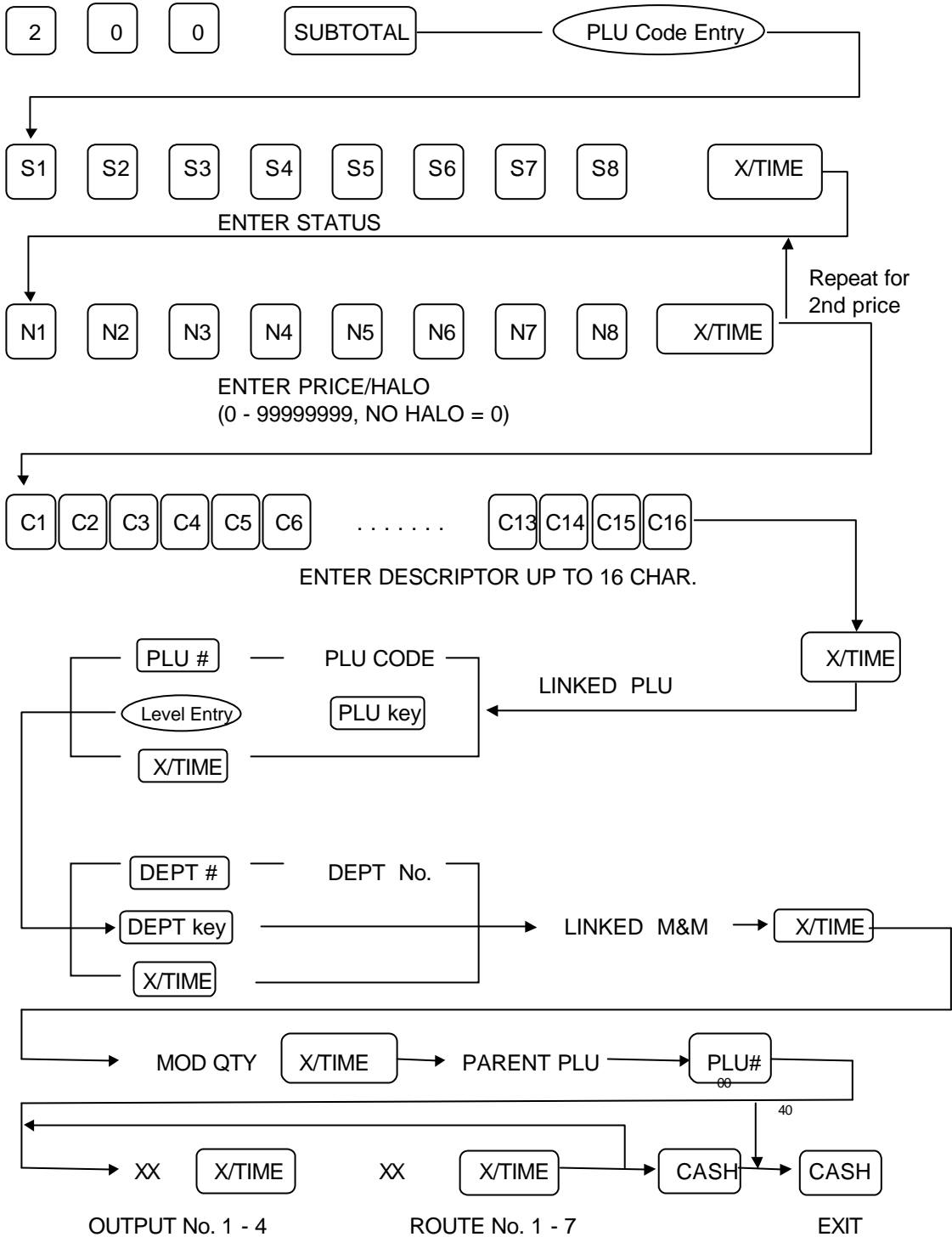

PLU PROGRAMMING

Batch PLU Deletion Programming

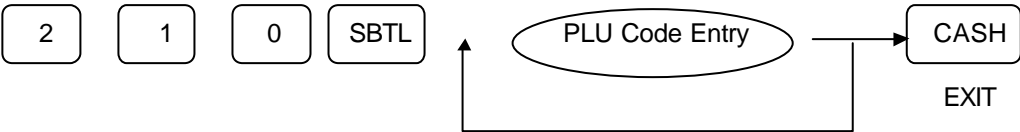

Clear Batch PLU



Run Batch PLU



* If you want to program or delete PLUs but not directly, then use batch plu features.
When you need to activate the batch programmed or deleted PLUs, execute run batch plu function.
Then the batch PLUs which stored in the memory buffer will be programmed or deleted.

* PLU which has amount or count in Z1, Z2 or Z3 report can not be deleted.

DEPARTMENT PROGRAMMING

Department access method 1:-

Using DEPT# key



Department access method 2:-

Using X/TIME key

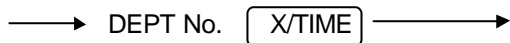

Department access method 3:-

Using DEPT key on the keyboard



DEPARTMENT PROGRAMMING

DEPARTMENT PROGRAMMING (All Parts)

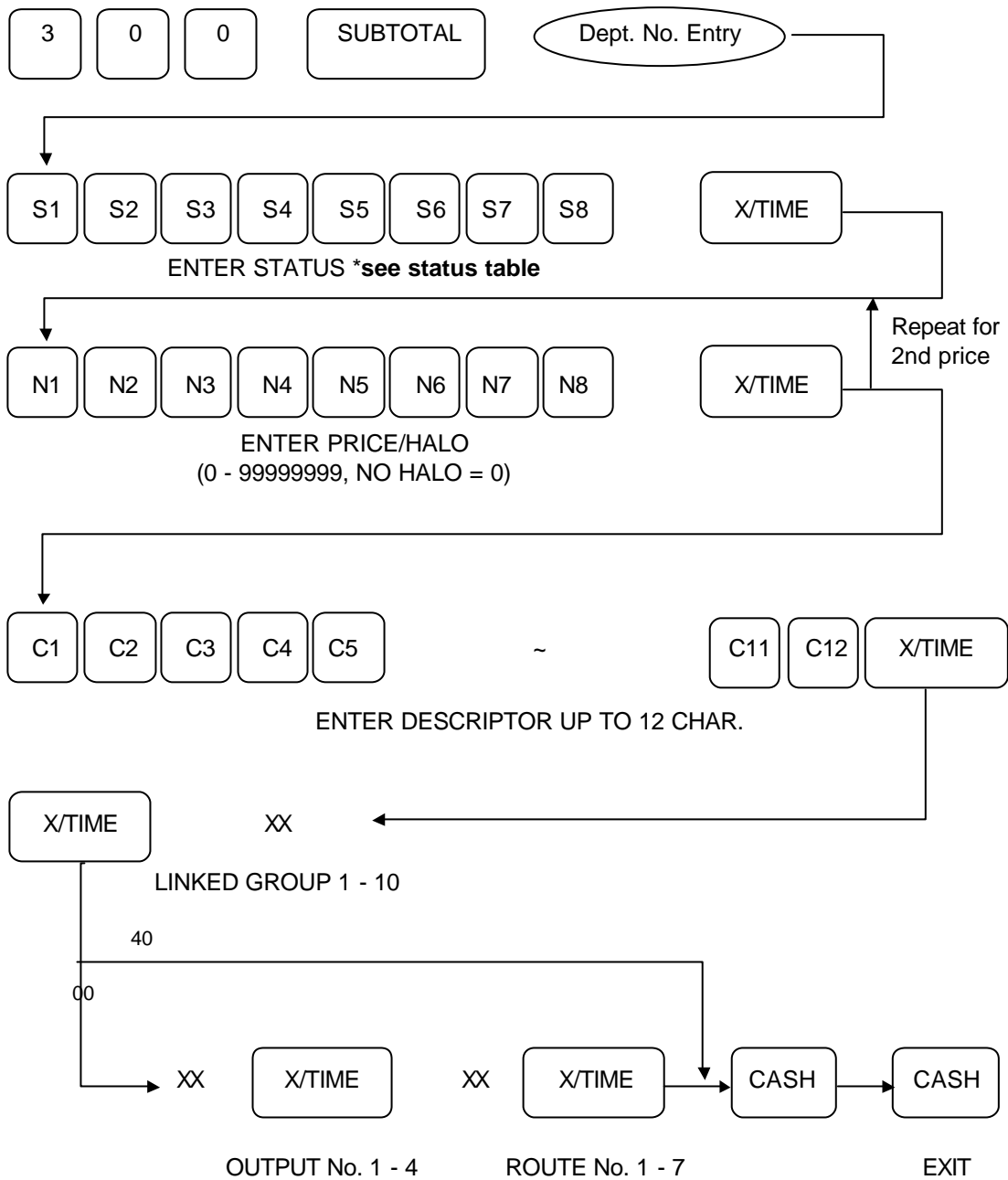

DEPARTMENT PROGRAMMING

Status table

Addr.	DEPARTMENT PROGRAM OPTION	VALUE	=	SUM
1	DEPT is Taxable by Rate 1	YES = 1 / NO = 0	A	A+B+C
	DEPT is Taxable by Rate 2	YES = 2 / NO = 0	B	
	DEPT is Taxable by Rate 3	YES = 4 / NO = 0	C	
2	DEPT is Taxable by Rate 4	YES = 1 / NO = 0	A	A+B+C
	DEPT is Not Discountable	YES = 2 / NO = 0	B	
	DEPT is a Condiment ⁰⁰	YES = 4 / NO = 0	C	
3	DEPT is Negative	YES = 1 / NO = 0	A	A+B+C
	DEPT is Single Item	YES = 2 / NO = 0	B	
	DEPT is Hash DEPT	YES = 4 / NO = 0	C	
4	DEPT is Gallonage DEPT *	YES = 1 / NO = 0	A	A+B+C
	Enable DEPT Price Change	YES = 2 / NO = 0	B	
	Enable Zero Price DEPT Sale	YES = 4 / NO = 0	C	
5	Compulsory Non-Add Entry	YES = 1 / NO = 0	A	A+B+C
	Compulsory Validation	YES = 2 / NO = 0	B	
	Compulsory Condiment Entry ⁰⁰	YES = 4 / NO = 0	C	
6	DEPT does not Print on Receipt	YES = 1 / NO = 0	A	A+B+C
	DEPT does not Print on Detail	YES = 2 / NO = 0	B	
	DEPT Prints Red on Kitchen Printer ⁰⁰	YES = 4 / NO = 0	C	
7	DEPT Prints on KP ⁰⁰	YES = 1 / NO = 0	A	A
8	DEPT is Preset	YES = 0	A	A+B
	DEPT is Open	YES = 1		
	DEPT is Disabled	YES = 2		
	Disable PROMO on this DEPT	YES = 4 / NO = 0		

* If this is set, the Department HALO has 3 digits under the decimal point.

Department Status Programming

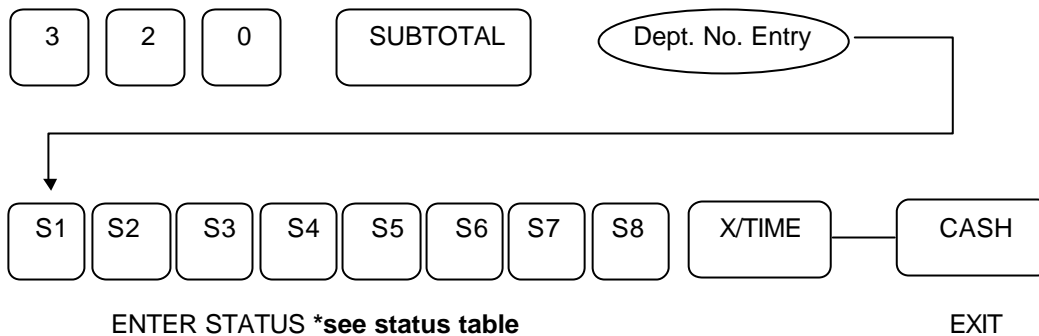

DEPARTMENT PROGRAMMING

Department Price/Halo Programming

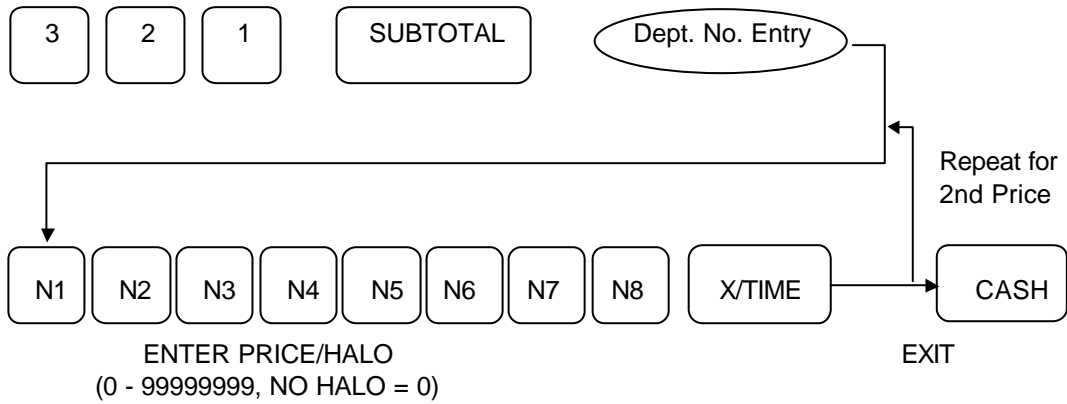

Department Descriptor Programming

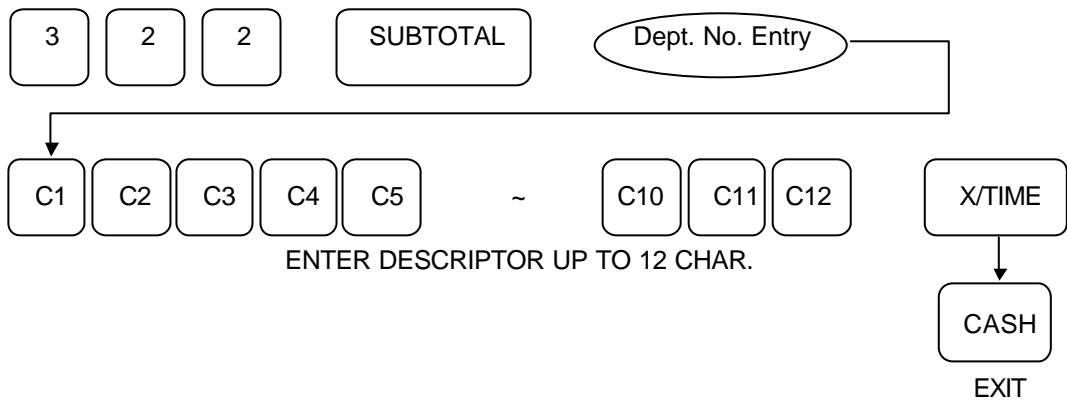

Department Link Group Programming

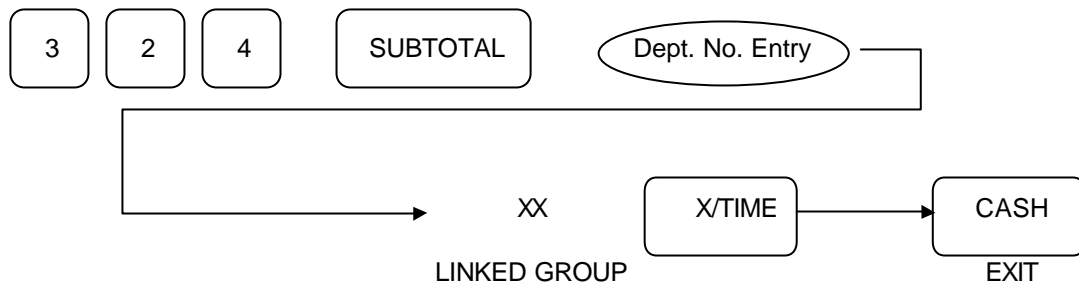

DEPARTMENT PROGRAMMING

Department Kitchen Printer Programming⁰⁰

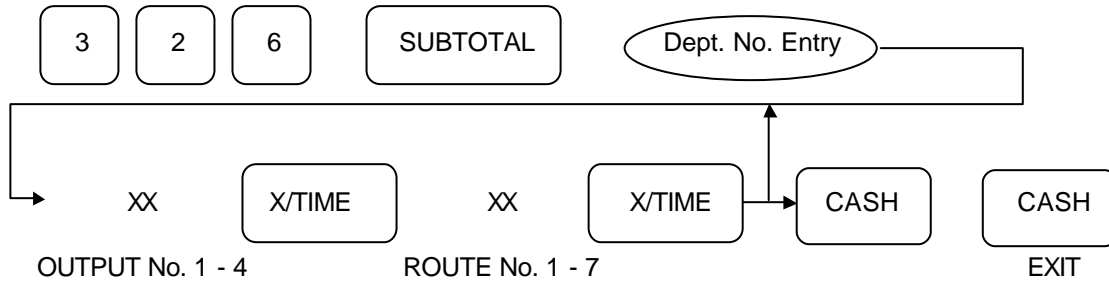

NON PLU PROGRAMMING

This option is used for scaleable barcodes

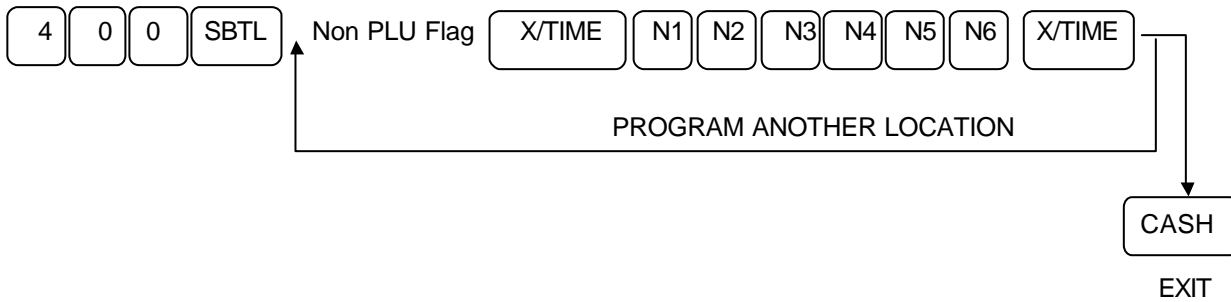

Non PLU Flag : 02, 20 ~ 29

	Meaning	VALUE
N1	Length of field 1	0 - 9
N2	Length of field 2 (Price)	0 - 9
N3	Contents of field 1	Dept. No. = 1 / PLU Code = 0
N4	Future use	
N5	Price check digit used	Yes = 1 / No = 0
N6	Tab or decimal point position of field	X.XX = 0
		XX.X = 1
		XXX. = 2
		X.XXX = 3

The Non PLU code format is as follows :

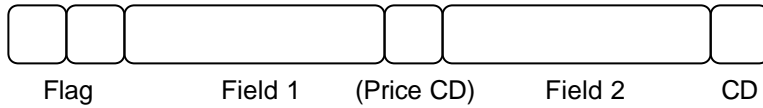

PLU PLACEMENT PROGRAMMING (NLU PROGRAMMING)

This will allocate PLUs to the keyboard

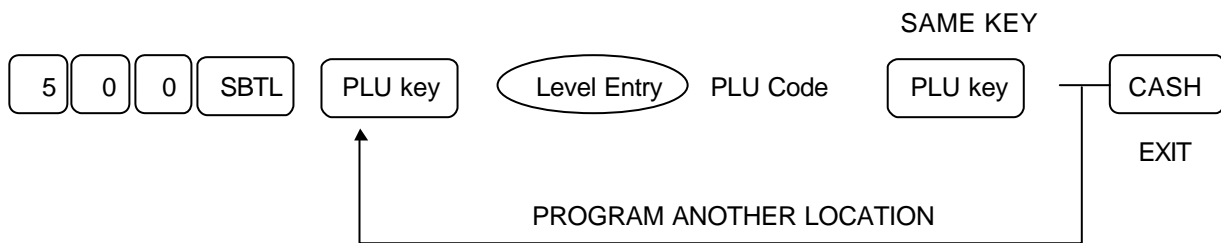

SET MENU PROGRAMMING

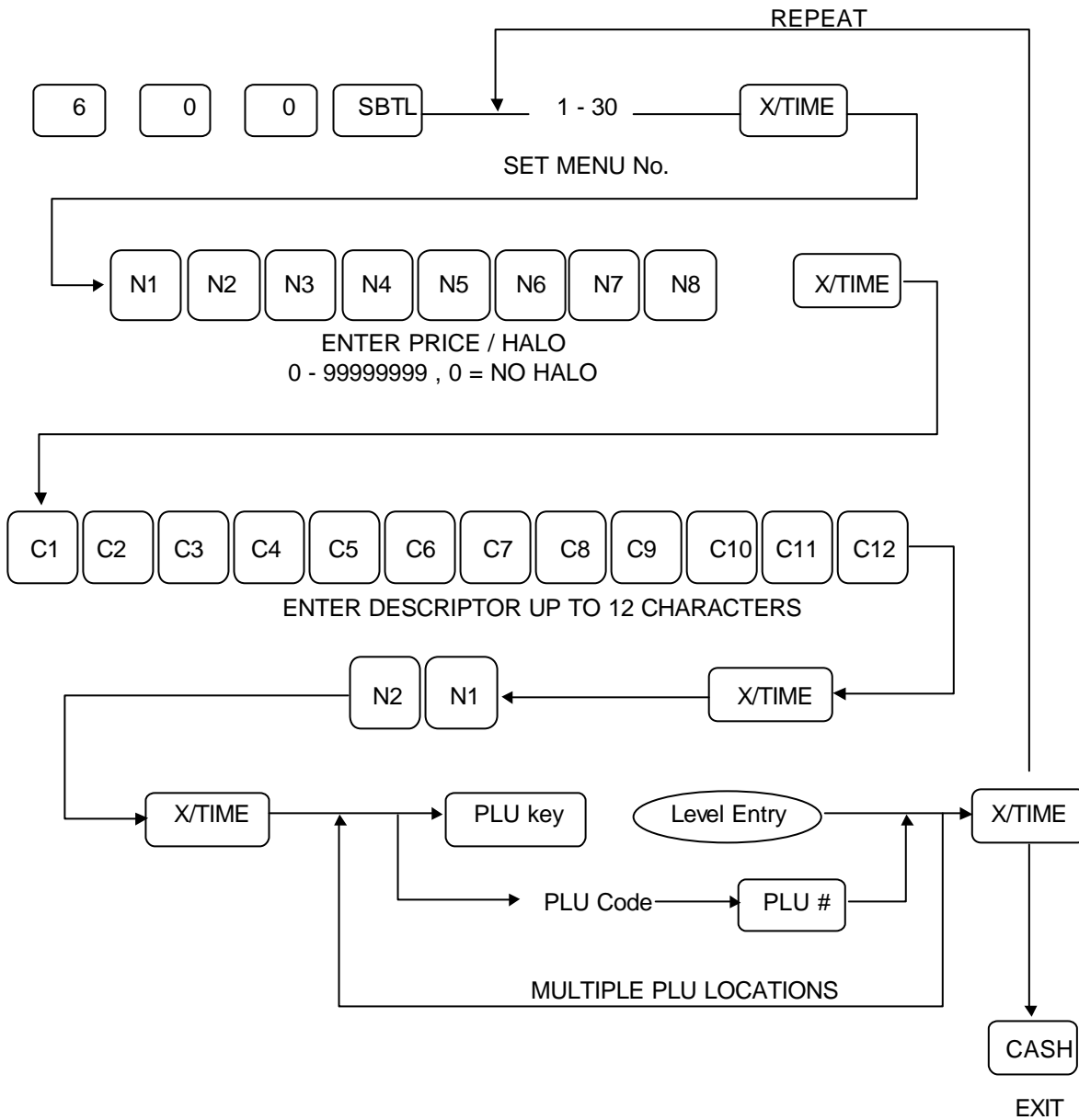

	KEY OPTION	VALUE	=	SUM
N1	Taxable by rate 1	YES = 1 / NO = 0	A	A+B+C
	Taxable by rate 2	YES = 2 / NO = 0	B	
	Taxable by rate 3	YES = 4 / NO = 0	C	
N2	Taxable by rate 4	YES = 1 / NO = 0	A	A

MIX & MATCH TABLE PROGRAMMING

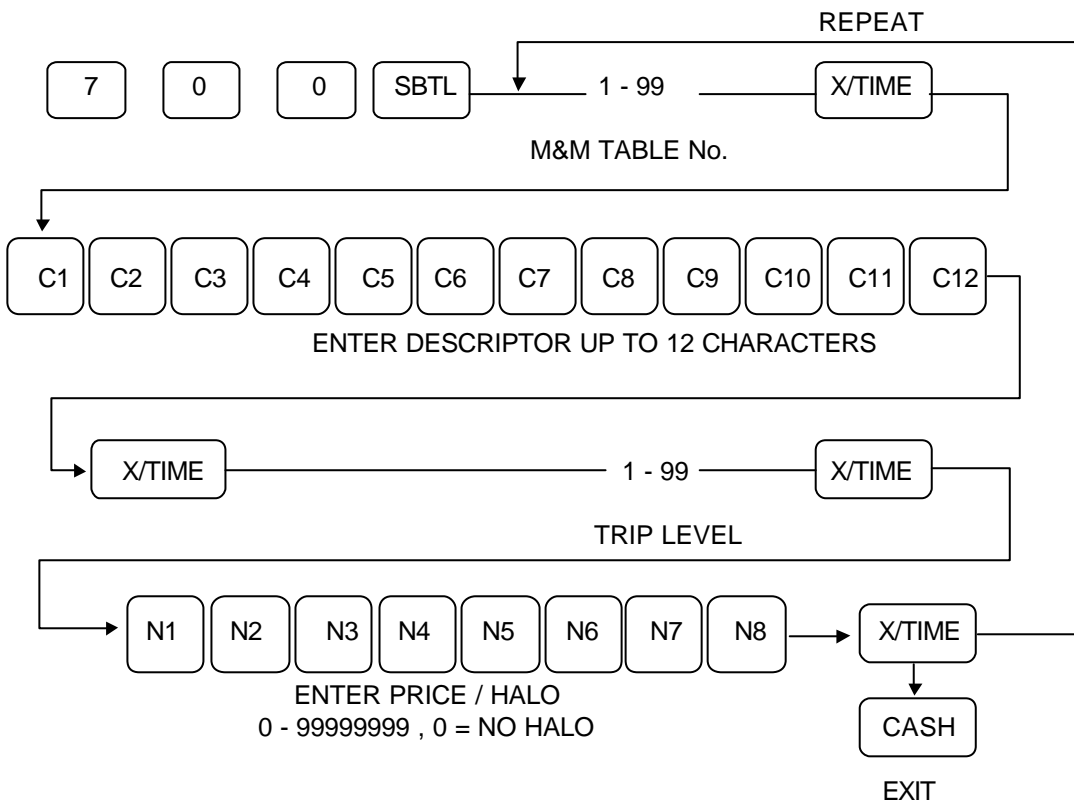

CLERK PROGRAMMING

Clerk Secret Code Programming

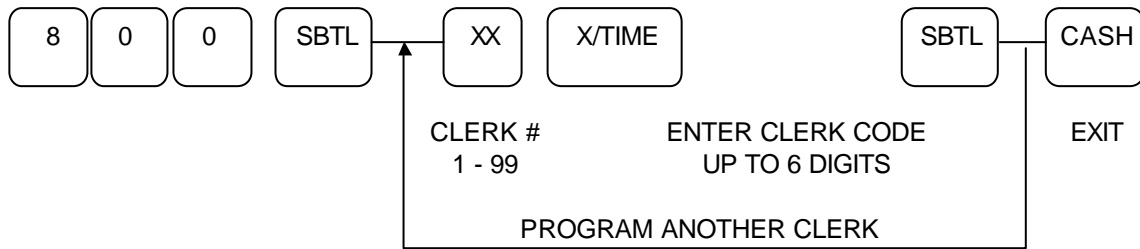

Clerk Descriptor Programming

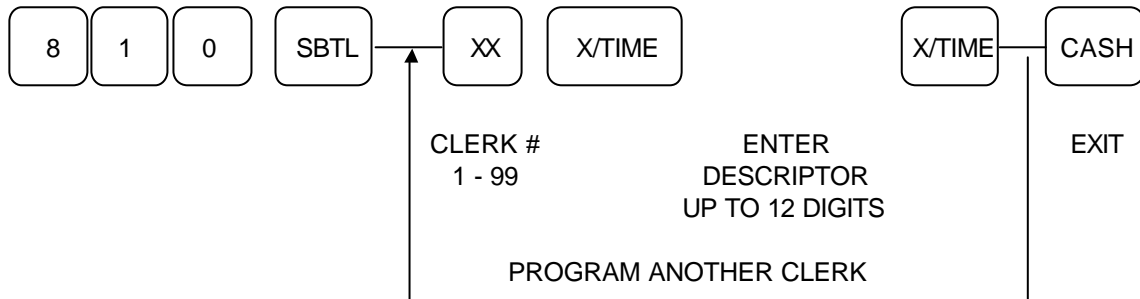

Clerk Status Programming

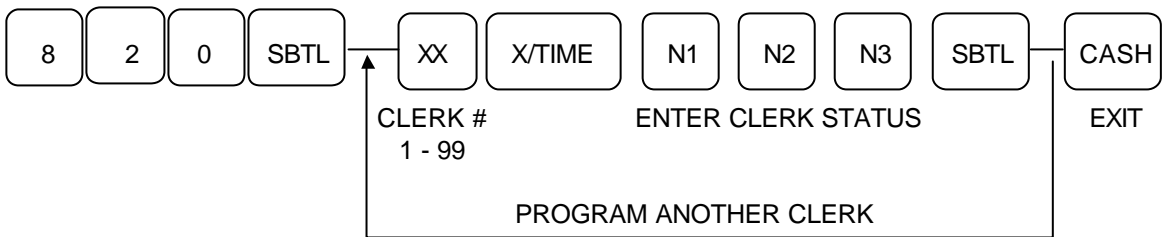

	Meaning	VALUE
N1, N2	LABOUR GROUP	1 - 30
N3	DRAWER ASSIGNMENT	1 - 3

GROUP PROGRAMMING

Normal Group Descriptor Programming

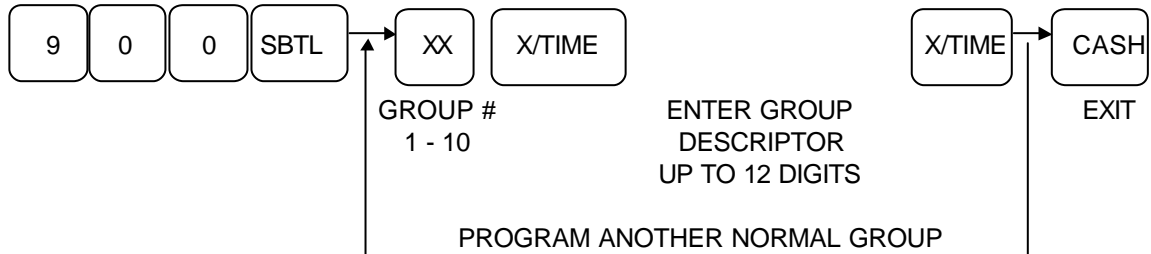

Normal Group Status Programming

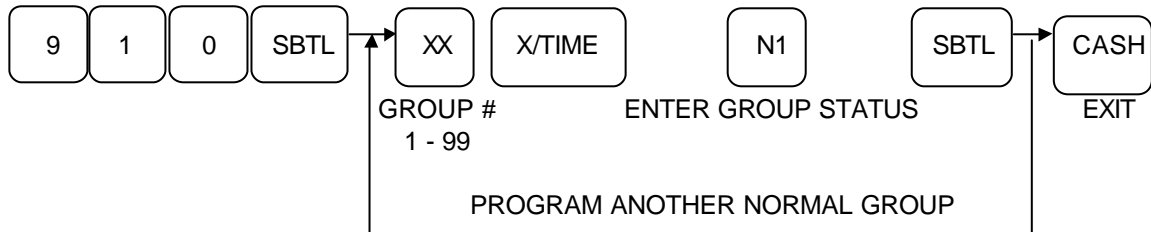

	Meaning	VALUE
N1	GROUP DOES NOT ADD TO GROUP TOTAL	YES = 1 / NO = 0

KITCHEN PRINTER ROUTE PROGRAMMING ⁰⁰

Kitchen Printer Route Programming

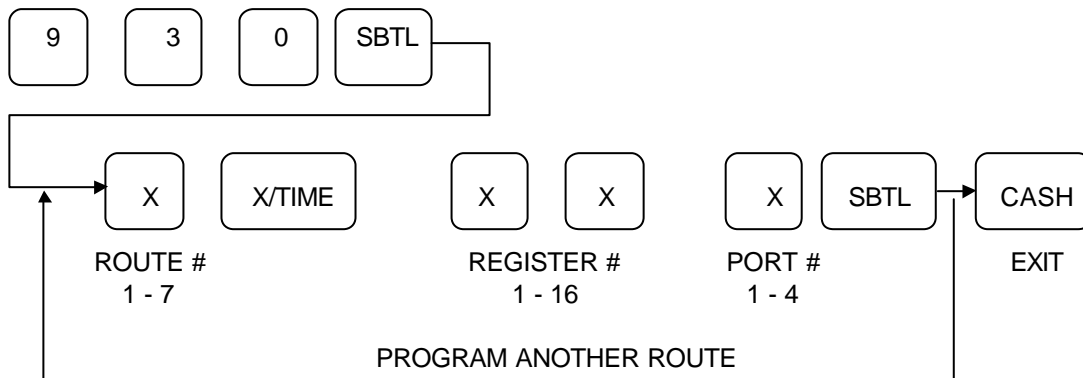

Kitchen Printer Route Back-Up Programming

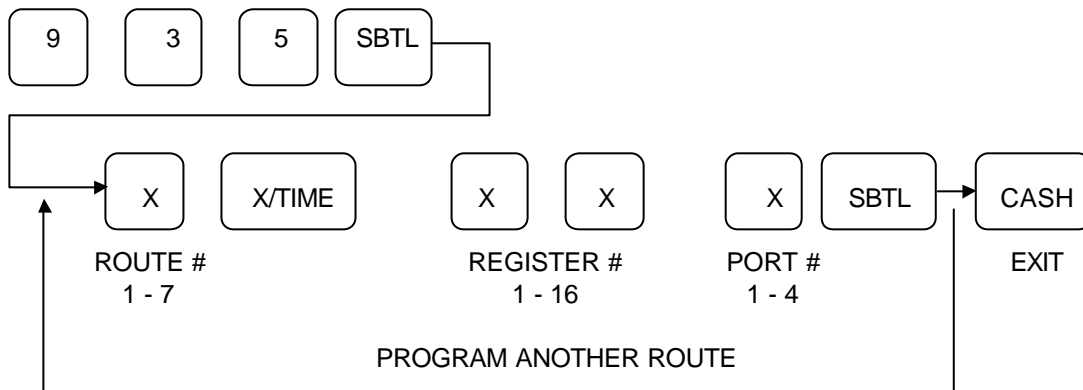

Kitchen Printer Descriptor Programming

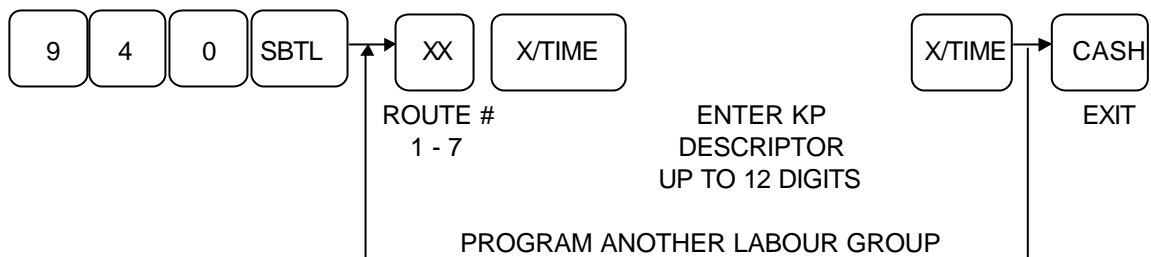

Financial Report Message Programming

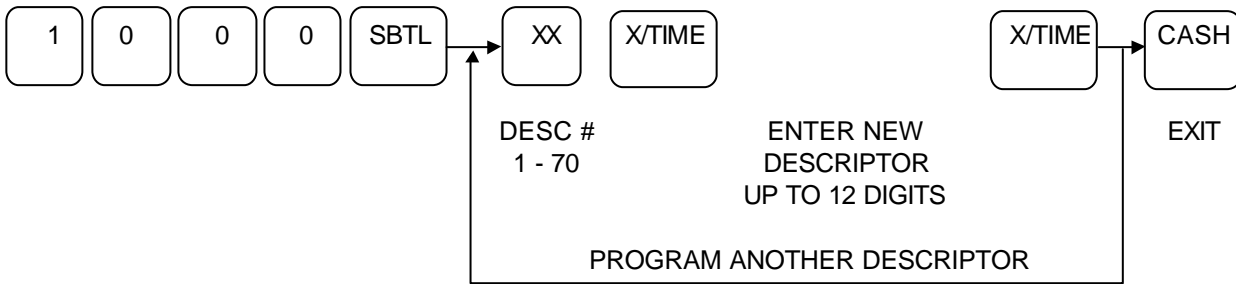

Display / Print Descriptor Programming

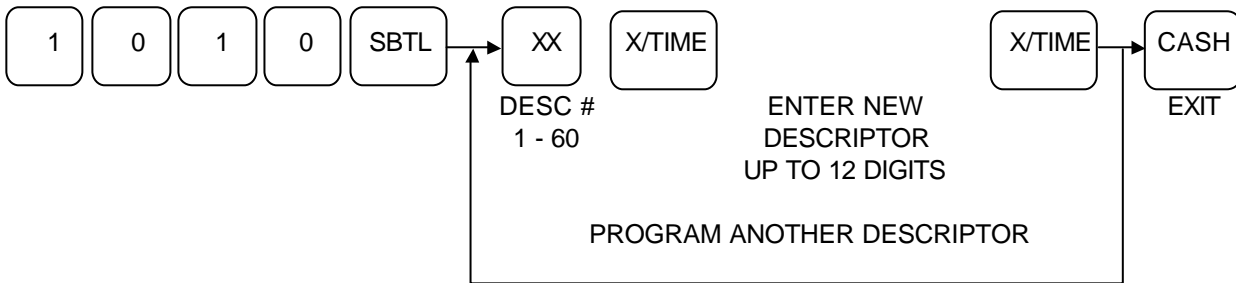

Error Message Programming

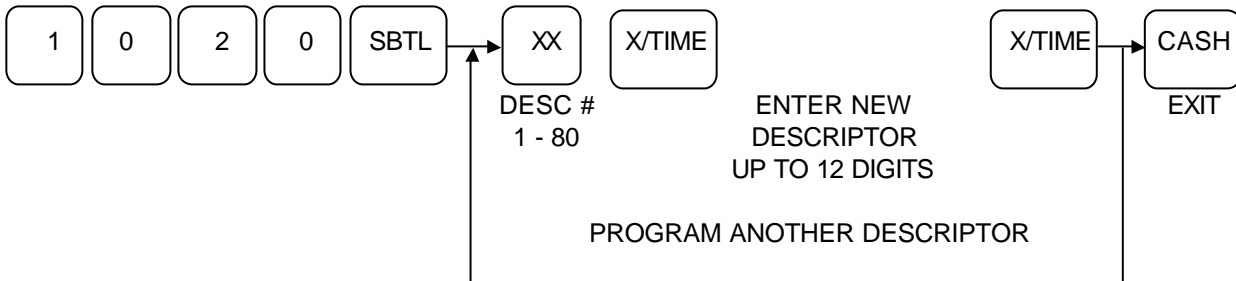

Clerk Report Message Programming

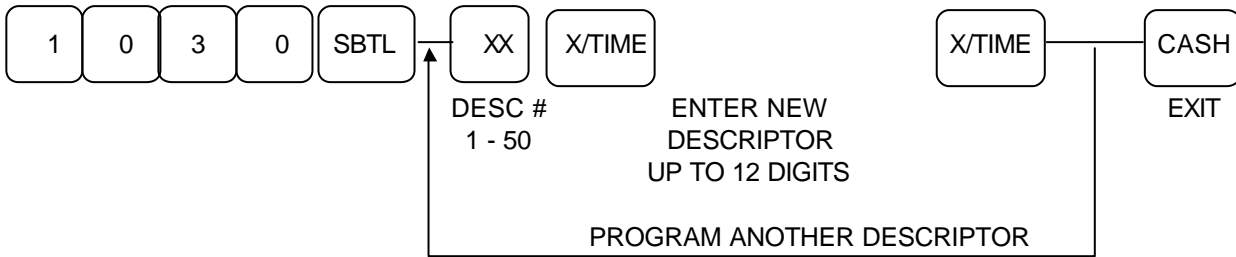

Logo Message Programming

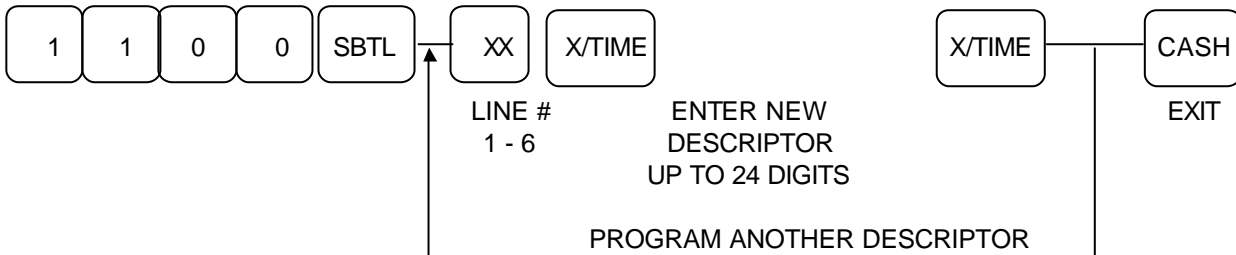

LOGO # 1 - # 4 ARE PRE-AMBLE
 LOGO # 5 - # 6 ARE POST-AMBLE

RECEIPT EXAMPLE

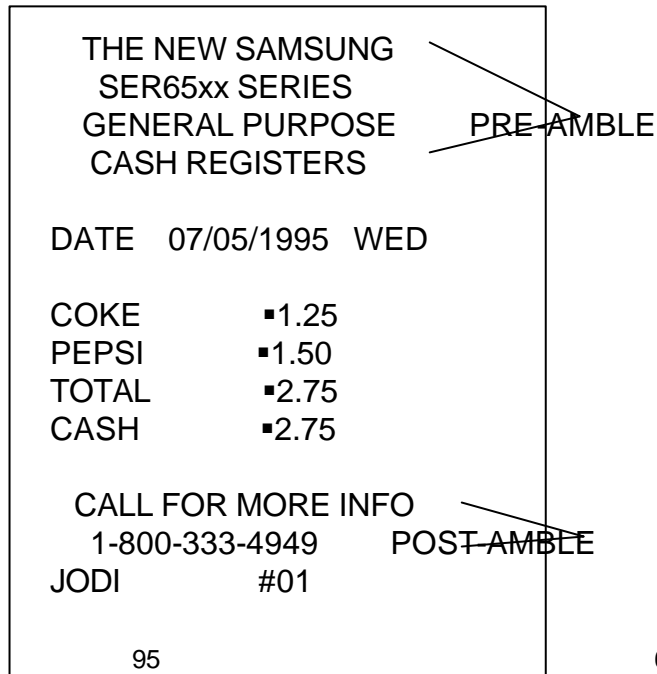

DISPLAY PRINT DESCRIPTOR DEFINITIONS

1. TIME - Printing message.
2. DATE - Printing message.
3. CHANGE - Printed on receipt to show the amount to change.
4. TOTAL - Printed on receipt to show the total amount.
5. NON-ADD NO. - Printed on receipt to show non-add number.
6. R/A TOTAL - Printed on receipt to show the total upon completion of a Received on Account operation.
7. P/O TOTAL - Printed on receipt to show the total upon completion of a Paid Out operation.
8. DISCOUNT - Not used currently.
9. SALE DISC - Not used currently.
10. SURCHARGE - Not used currently.
11. SALE SURC - Not used currently.
12. AMOUNT - Printed on receipt to show the amount of discount.
13. CLK LOGIN : - Printed on receipt to show the name of the clerk logging into the system.
14. CLK LOGOUT: - Printed on receipt to show the name of the clerk logging out of the system.
15. TIME CLKIN: - Printed on receipt to show the clock-in time. (Time keeping function)
16. TIM CLKOUT: - Printed on receipt to show the clock-out time. (Time keeping function)
17. TIME IN : - Printed on timekeeping report.
18. TIME OUT : - Printed on timekeeping report.
19. TAXABLE 1 - Printed on receipt to show the amount taxable at rate 1.
20. TAXABLE 2 - Printed on receipt to show the amount taxable at rate 2.
21. TAXABLE 3 - Printed on receipt to show the amount taxable at rate 3.
22. TAXABLE 4 - Printed on receipt to show the amount taxable at rate 4.
23. TAX AMT 1 - Printed on receipt to show the tax 1 amount added.
24. TAX AMT 2 - Printed on receipt to show the tax 2 amount added.
25. TAX AMT 3 - Printed on receipt to show the tax 3 amount added.
26. TAX AMT 4 - Printed on receipt to show the tax 4 amount added.
27. NET 1 AMT - Printed on receipt to show the net amount taxable at VAT rate 1.
28. NET 2 AMT - Printed on receipt to show the net amount taxable at VAT rate 2.
29. NET 3 AMT - Printed on receipt to show the net amount taxable at VAT rate 3.
30. NET 4 AMT - Printed on receipt to show the net amount taxable at VAT rate 4.
31. FOREIGN AMT - Printed on receipt to denote the amount in foreign currency.
32. HOME AMT - Printed on receipt to denote the amount in home currency.
33. CHANGE RATE - Printed on receipt to show the currency rate.
34. GAS CNT - Number of gallons pumped (in case of gallonage PLUs) printed on receipt.
35. GAS AMT - Price per gallon (in case of gallonage PLUs) printed on receipt.
36. SCPN AMT - Store Coupon amount printed on receipt.
37. TAX TOTAL - Total combined taxes charged for this sale(when single tax line is printed.)
38. BFWWD - (Balance Forward) printed on guest check and displayed above amounts carried forward in a check tracking environment.
39. CKPD - (Checks Paid) printed on guest check and displayed above amounts carried being paid in a check tracking environment.
40. SIGN ON - Displayed when a clerk press TIME IN/OUT key to clock in.
41. CHANGE - Displayed above change amount.
42. TIME IN - Displayed when a clerk clocks in.
43. SUBTOTAL - Displayed when SUBTOTAL key is depressed.
44. COUPON - Displayed above coupon amount when coupon key is depressed.
45. NON-ADD # - Prompt displayed for compulsory non-add entry.

DISPLAY PRINT DESCRIPTOR DEFINITIONS

- 46. OPEN AMOUNT - Prompt displayed after PLU code is entered for PLUs programmed as open.
- 47. POST TENDER - Displayed while performing post tender operations.
- 48. INS PAPER - Prompt displayed when validation is required.
- 49. VALIDATION! - Prompt displayed if you try and ignore the one above.
- 50. ADD CHECK - Displayed when add check feature is finished.
- 51. TRANS CHECK - Displayed when transfer check feature is finished.
- 52. SIGN ON - Displayed when the keylock is in the REG/VOID position, and a clerk is signed off.

- 53. VD MODE - Displayed when the keylock is in the VOID position.
- 54. OFF MODE - Displayed when the keylock is in the OFF position.
- 55. REG MODE - Displayed when the keylock is in the REG position.
- 56. X - Displayed when the keylock is in the X position.
- 57. Z - Displayed when the keylock is in the Z position.
- 58. PGM - Displayed when the keylock is in the PGM position.
- 59. S MODE - Displayed when the keylock is in the S position.
- 60. X REG MODE - Displayed when the keylock is in the X position and the register is in the middle of transaction.

- 61. CRR1 CHANGE - Printed to denote currency conversion change at rate 1.
- 62. CRR2 CHANGE - Printed to denote currency conversion change at rate 2.
- 63. VOID MODE - Printed at the top of receipt created while in VOID mode.
- 64. TRAIN MODE - Printed at the top of receipt created while in VOID mode.

ERROR MESSAGE DESCRIPTOR DEFINITIONS

1. BUFF. FULL - The buffer for check has reached capacity.
2. REQ AMOUNT - This operation requires an amount entry.
3. NO PLU! - The number entered is not a valid PLU.
4. HALO OVER - The amount entered exceeds the programmed HALO.
5. INACTIVE! - The key pressed is inactive or VOID mode is inactive.
6. F-STAT ERR - Function key status is wrong.
7. REQ GAL AMT - This entry involves a gallonage PLU, and requires an amount entry.
8. NEGATIVE - This sale has gone negative. Negative sale is not allowed.
9. REQ COND! - This item has been programmed to require a condiment entry.
10. NOT PGMMED! - This key has not been programmed.
11. OVERRIDE X - The keylock has to be moved to the X-Mode in order to override an HALO amount, or other restriction.
12. NO OVERRIDE - X-Mode override is not allowed.
13. NO MANUAL - Manual entry is not allowed (scale function).
14. SYS-OPN ERR - System option is wrong.
15. OPEN DRAWER - The register has been programmed not to operate with the cash drawer open.
16. NO LINK PLU - Number of linked PLU is over 20 or linked PLU is not found.
17. NO SINGLE! - This PLU has been programmed as a single item PLU and can not be used within a sale.
18. REQ NONADD# - This operation requires the entry of a Non-Add number.
19. ZERO AMT - The register has been programmed to not allow negative sales, and to consider a zero amount as a negative sale.
20. REQ ADDCHK - Not used currently.
21. REQ R/A! - The operator is in the middle of a received on account operation, which requires a final depression of the R/A key to finalize the operation.
 - The operator is in the middle of a paid out operation, which requires a final depression of the P/O key to finalize the operation.
22. REQ P/O! - This operation requires validation.
23. REQ VALID - This operation requires a depression of either EAT-IN, TAKE-OUT or DRIVE-THRU keys.
24. REQ EAT-IN
25. REQ SCL PLU - Not used currently.
26. REQ SCALE - This item requires an amount entry via SCALE key (either auto or manual)
27. K-PRN FAIL The kitchen printer has failed to respond.
28. SEQ.ERROR - The preceding key sequence is not allowed.
29. REQ TARE# - This PLU/scale item requires a tare weight entry.
30. CASH-I-OVER - The Programmed Cash-In-Drawer limit has been exceeded.
31. REQ SUB KEY - The SUBTOTAL key must be depressed before continuing.
32. CHECK# AUTO - The operator has attempted to open a new guest check by assigning a check number. The register has been programmed to generate its own check numbers.
33. REQ TABLE# - Table number entry is required to open a guest check.
34. REQ GUEST# - The operator must enter the number of guests when opening a guest check.
35. NOT DISCNT - The preceding entry is not discountable.
36. NO SAME CLK - The clerk attempting to open this guest check is not the original clerk who started the guest check.

ERROR MESSAGE DESCRIPTOR DEFINITIONS

- 37. NO DATA - The PLU can not be found. This message is displayed other than REG mode.
- 38. NO CHECK # - The check can not be found.
- 39. COMP XMODE! - This operation requires the keylock to be turned to the X position.
- 40. CHANGE BACK - Money has declared for received on account..
- 41. USING! - The check is being used.
- 42. OFF LINE! - IRC communication is off line.
- 43. NOT READY! - Remote printer is not ready.
- 44. NOW REAL! - Not used currently.
- 45. CLK INT ERR - An error has occurred while clerk interrupt.
- 46. SIGN OFF - Current operator has to sign off to sign on another operator if signon method is using clerk secrete code.

- 47. REQ DEPT LK - Department link is compulsory.
- 48. REQ GRP LK - Group link is compulsory.
- 49. HALO ERROR - The number length is differ that is defined in the NS key HALO.
- 50. TENDER AMT - Amount is compulsory at tender.
- 51. SYSTEM ERR - Normal error.
- 52. RANGE OVER - The number entered is out of range.
- 53. E MODE - The keylock is in the wrong position.
- 54. OPERATION - The operator has used an illegal key sequence.
- 55. BAD VALUE - The number entered is wrong.
- 56. DUPLICATE - The check is already exist.
- 57. REQ SIGNON - Sign on required.
- 58. PAPER END - The guest check printer has reached the of the form.
- 59. MEMORY FULL - Memory is full.
- 60. BAD FUNC - Memory file number is wrong.
- 61. BUSY - Destination register is busy.
- 62. M&M ERR - An error has occurred while mix and match operation.
- 63. NOT ZERO - The PLU operator attempts to delete has sale count/amount.
- 64. NO DRAWER! - The drawer is no longer attached and is required in order to continue.
- 65. NO PAPER - Slip printer is out of paper.
- 66. REQ WASTE - The operator is in the middle of a waste operation, and must depress the WASTE key in order to complete the operation.

- 67. REQ P/BAL - The register has been programmed to operate as a pre-check machine, and requires a previous balance entry.
- 68. REQ CHECK# - This register has been programmed to allow manual check number entry to begin a guest check transaction.
- 69. REMOV PAPER - Validation is complete and the form must be removed.
- 70. REQ CA DEC - Cash declaration has been programmed as compulsory, and must first be performed before reports may be generated.

- 71. CRC ERROR - An error has occurred in block checksum.
- 72. ZERO PRICE - Zero price item sale is not allowed.
- 73. ERROR - General error message.

STRING REPORT PROGRAMMING

SEQUENCE OF REPORTS

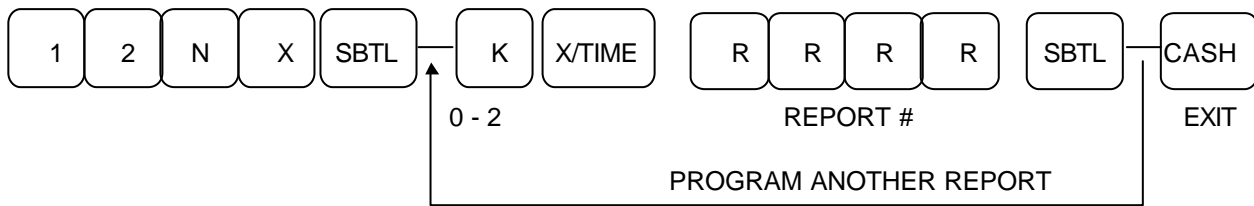

N = STRING REPORT # (1-5)

X = 0 : NON-IRC REPORTS
1 : IRC REPORTS

K : KEYLOCK POSITION
0 = ACTUAL
1 = X-MODE
2 = Z-MODE

TIME SCHEDULE FOR STRING REPORT

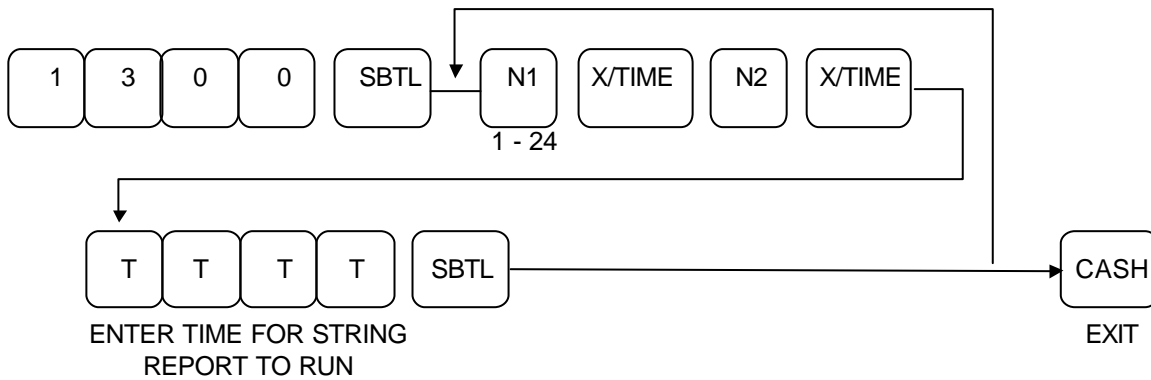

N1 : THE STRING REPORT CAN BE PROGRAMMED TO RUN UP TO 24 TIMES IN ONE DAY.

N2 : STRING REPORT #

ENTER TIME IN MILITARY

EXAMPLE : 2300 = 11:00PM

9999 = NO SCHEDULE (THIS IS THE DEFAULT SETTING)

Note:- Please set within P-mode communications settings the register which is to activate the timed function

MENU LEVEL SCHEDULE PROGRAMMING

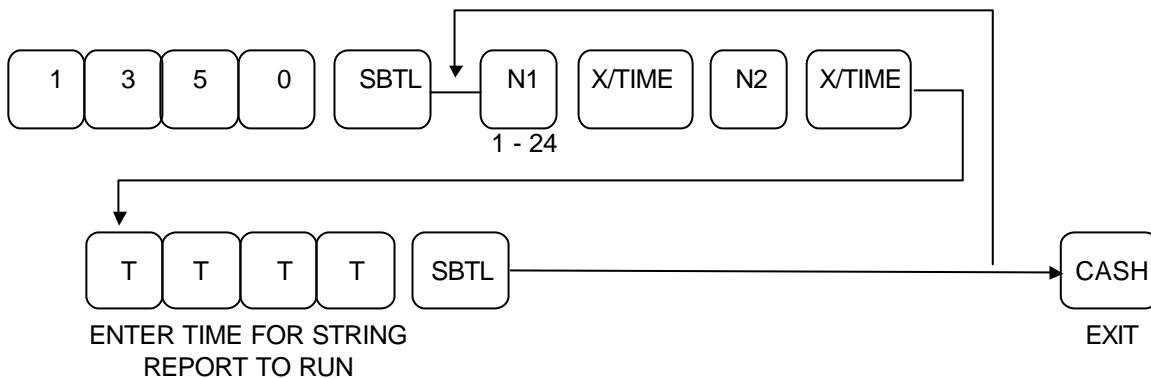

N1 : THE LEVEL INDEX WHICH CAN BE PROGRAMMED TO RUN UP TO 24 TIMES IN ONE DAY.

N2 : MENU LEVEL (1 FOR LEVEL1 ~ 3 FOR LEVEL3)

ENTER TIME IN MILITARY

EXAMPLE : 2300 = 11:00PM

9999 = NO SCHEDULE (THIS IS THE DEFAULT SETTING)

TIME SCHEDULE FOR STRING REPORT

Reset Time Scheduler

To cancel all time schedulars follow the procedure below:-

Program Position

1310

Reset Menu Scheduler

To cancel all menu Scheduler follow the procedure below:-

Program Position.

1360

DATE AND TIME PROGRAMMING

1 4 0 0 SBTL

D D M M Y Y H H M M X/TIME

Date programming

1 4 0 1 SBTL D D M M Y Y X/TIME

Time programming

1 4 0 2 SBTL H H M M X/TIME

PROGRAM DOWNLOAD.

Use this function, if you need to downloading data from a register to others.

Operation

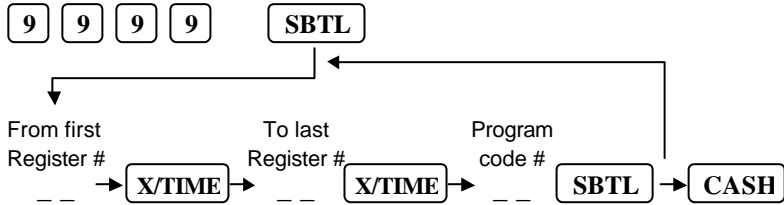

Program code

NO.	PROGRAM	NO.	PROGRAM
1	GROUP	16	LOGO MESSAGE
2	DEPARTMENT	17	MACRO
3	FUNCTION KEYS	18	STRING REPORT
4	P - MODE PROGRAM OPTION	19	TAX TABLE
5	P - MODE PRINTING OPTION	20	MIX AND MATCH TABLE
6	S - MODE PROGRAM OPTION	21	NOT FOUND PLU
7	P - MODE COMMUNICATION OPTION	22	SET MENU
8	KEY LINK TABLE	23	NON PLU ⁴⁰
9	NLU	24	BATCH PLU
10	TIME SCHEDULE	25	LABOUR GROUPS
11	LEVEL SCHEDULE	45	CLERK
12	DISPLAY DESCRIPTOR	55	PLU
13	ERROR MESSAGE	99	DOWNLOADING ALL PGM
14	REPORT/RECEIPT DESCRIPTOR	100	DATE AND TIME
15	CLERK REPORT DESCRIPTOR		

OPERATION MODE

Introduction

The operation section of this manual gives basic information about the functions performed by the register. Each of the register keys are explained, giving a general description of their operation.

Example operations are given for each function key showing correct keystrokes. Since all machines differ in the actual programming, the operation of some keys may require a management key, while other optional keys may not exist on your keyboard.

Note : Before using this System Electronic Cash Register for the first time, leave it powered On in the "REG" position mode for at least twenty-four hours. This allows the Ni-Cad battery, which maintains the memory while the power is OFF, to fully charge.

FUNCTION OF MODE CONTROLS

Off (lock position)

This position locks the register from operation. The key can be removed in this position

Register

This position is the normal position for registration. The key can be removed in this position.

X Position

Used to obtain reports without resetting any totals. Also, used for special operations including the operation of manager controlled function keys and training mode.

Z Position

Used to obtain reports while resetting (clearing) any total data.

Void Position

Used for voiding sales with the added security of the key positioning

P-Mode

Used for standard programming functions. Changing prices, descriptions etc.

S-Mode

Used for system programming functions.

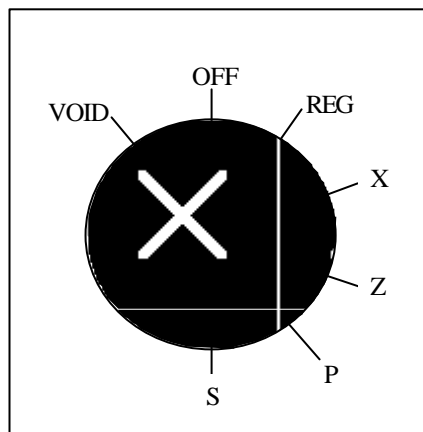

KEY DESCRIPTION

Numeric Keys :

0,1,2,3,4,5,6,7,8,9,00 are used to input numeric data (amount, quantity, program codes etc.)

Cash Key

This key is used to finalize a Cash transaction. When it is pressed, the total amount of the transaction is calculated. At the same time, a receipt can be issued and the Cash Drawer opened. The total amounts are added to the specific reports as applicable. If the amount tendered is entered into the register and this exceeds the total amount of the sale then the change will be calculated and displayed on the screen.

Cheque Key

This key is used to finalize a Cheque transaction. If the amount tendered is entered into the register and this exceeds the total amount of the sale then the change will be calculated and displayed on the screen.

Charge# key

This key is used to finalize one of eight types of Charge transaction.

Charge 1 ~ 10 keys

These keys are used to finalize a Charge transaction. Up to 10 Charge keys are available.

Cur Conv1 and Cur Conv2 keys

The Currency conversion keys are used to convert a subtotal figure into foreign currency using an exchange rate preset to each key. When this key is pressed, the register enters the currency exchange mode, and subsequent amount entries are regarded as foreign currency.

%1 - %10 keys. (Discount, surcharge etc.)

These keys can be programmed for monetary discount, monetary surcharge, percentage discount and percentage surcharge, etc.

Err Correct key

This key is used to invalidate the immediately preceding registration. The key must be pressed immediately after the incorrect entry.

Void key

This key is used to invalidate previously registered data. This operation must be made before the end of the transaction.

Cancel key

This key is used to completely cancel the last sale. If a transaction is canceled none of the totals are updated.

P/O key

This key is used to record amounts paid out from the register. Amounts Paid Out will be deducted from Cash In Drawer total.

R/A key

This key is used to register cash received other than sales transactions. Amounts Received On Account will be added to the Cash In Drawer total.

MDSE Return key

This key is used to register refunded goods in the registration position. This function is available for returns to Departments and PLU's. It will also return any tax which may be applicable.

KEY DESCRIPTION

Exempt Tax key

This key is used to change the tax status of the proceeding sale item.

Eat In /Take Out/Drivethru keys

These keys are used to provide sales data on the various type of transaction. i.e. where the goods are taken out?. For areas that have different tax rules the tax charges may be exempt.

Print key

This key enables any items to be printed to a kitchen printer even when the item is not preset to print to a printer.

/ No sale key

The #/No Sale key is used as a non-add key, and prints up to a 7 - digit numeric entry on the receipt and journal. This entry will not add to any sales total. The #/No Sale key is also used for No Sale operations to simply open the cash drawer.

Cheque - Cash key

This key is used to Cash Cheques and provide a facility to transfer sales information from/to the necessary totalizers

Promo key

This key is used to sell an items at no charge.

Waste key

This key is used to write off items.

Time In/Out key

This key is used to Clock In / Out clerks. Information regarding the hours a clerk has worked is stored in the registers memory.

Cashier#

This key is used to sign on/off a cashier. Either by Cashier Number or Secret Cashier Number.

Tax Shift

When this key is depressed before a department or PLU, the tax shift key reverses the tax shift of the department/PLU. i.e. a PLU with no tax status could be preset with Tax1, Tax2..... or All.

Add Check

This key is used to add a number of checks together

Separate Check

This key is used to separate a check so that the check can be paid for by a number of people.

Transfer Check

This key is used to transfer one check to another check number.

Sub-Total

This key displays the total of the sale including any tax calculation. It can be preset as compulsory if required.

X/Time

This key is used as a multiplication key or for displaying the time and date on the display.

Valid

This key is used to print a one line validation through the receipt/journal printer.

KEY DESCRIPTION

P/Bal

This key is used to input a previous balance.

Check#

This key is used in the check system to input a check number. The ECR can be programmed to generate a unique check number.

Table#

This key is used to enter a table number that can be printed on the customer bill or kitchen printer.

Guest#

This key is used to enter the number of guests at a table.

Service

This key is used to close transactions temporarily in a check system.

Print Check

This key is used to print the details of a check to either the receipt or bill printer.

Charge Tip

This key is used to input an amount of tips received.

Slip Print

This key is used to print the details of a check to the slip printer.

Price Change

This key enables the clerk to adjust the preset price of an item.

Open Price

This key is used to enter a price against an open PLU.

Price Enquiry

This key is used to enquire on the price of a item without registering the item.

Macro 1 ~ 10 Keys

Macro keys are used to execute a preset number of keystrokes automatically. A Macro can include another Macro if required.

Clerk#1 ~ 10 Keys

The clerk keys are used to sign a clerk on / off the ECR. They are also used for clerk interrupt operation.

Clear Key

Used to clear entries made on the keyboard. It is also used to clear error tones.

PLU#

This key is used to enter PLU (price look-ups) codes or bar-codes.

Dept#

This key is used to enter sales against a department that does not appear on the keyboard.

Post Receipt

If the receipt was turned off during a sale, this key will issue a receipt after the sale has been completed.

Receipt On / Off

Turns the Receipt On / Off

Set Menu#

Used to sell a Set Menu that is not on the keyboard.

Not Found PLU

If a PLU or barcode is not set-up on the ECR and an attempt is made to sell the product, by pressing the Not Found key the item can be programmed during registration for subsequent sales.

KEY DESCRIPTION

2nd Price

This key is used to sell the PLU or Barcode item at its second price.

Level #1, Level #2 and Level #3

These keys are used to change between menu levels

Set Menu 1 ~ 10

Used to sell a Set Menu item.

PLU 1 ~ 120

Used to assign a specific PLU number to the keyboard.

Dept 1 ~ 40

Used to assign a specific department to the keyboard.

CLERK SIGN ON

Clerk sign on/off

Key lock position : REG mode or VOID mode

There are 3 kind of clerk registration. These are push button clerk entry, real clerk key entry and clerk code entry.

Push button clerk entry (default)

If you select this system, clerks can register by pressing corresponding push button clerk key.

Clerk code entry

If you select this system, clerks can register by entering corresponding clerk code. There are two clerk code entry systems. (See P-Mode Program Option 33-A)

Clerk code entry with secret code

When the clerk code entry with secret code system is selected, clerks must enter their secret code to register.

Operation

* Sign on

----- Secret code (Max. 6 digit) which will not be displayed.

CASHIER

* Sign off (Simply press **CASHIER** key, then the clerk will sign off.)

CASHIER

CLERK SIGN ON

Clerk code entry with clerk number

When the clerk code entry with clerk code system is selected, clerks only enter their number to register.

Operation

* Sign on

-- Clerk code (1 - 99) which will be displayed.

CASHIER

* Sign off (Simply press **CASHIER** key, then the clerk will sign off.)

CASHIER

Real clerk key entry

If you select this system, clerks can register by inserting a corresponding real clerk key.
Max. 15 real clerk keys are available.

Clerk registration mode

Key lock position : REG mode or VOID mode

There are two modes in clerk registration. These are stay down mode and popup mode.
Refer to the P mode program option #5B for detail.

Stay down mode

If clerk is in stay down mode, clerk stays registered until the clerk signs off.

Popup mode

If clerk is in popup mode, clerk is automatically signed off when the clerk finalizes a transaction.

Floating clerk system

Key lock position : REG mode or VOID mode

This function will not work if P mode program option #5A and P mode communication option #6 are not programmed.

When floating clerk operation is enabled

To use this function you must set the floating clerk enable flag of the registers which run under floating clerk system.

When a clerk signs on a register under floating clerk system, the clerk is locked on other registers.
If a clerk sign on a register and attempts to sign on another register, error message "USING!" will be displayed and the clerk can not sign on.

When floating clerk operation is disabled

When floating clerk operation is disabled, a clerk can sign on registers simultaneously.

ITEM SALE ENTRIES

Item sale entries

Key lock position : REG mode

Direct entries

Enter a unit price and press a **DEPT** key or a **PLU** key.
If you use a programmed unit price, then press corresponding key only.

Operation

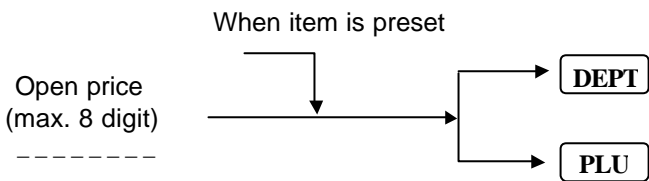

Indirect entries

Enter a item code and press a **DEPT#** key or a **PLU#** key when using a programmed unit price.
Otherwise enter open price together.

Operation

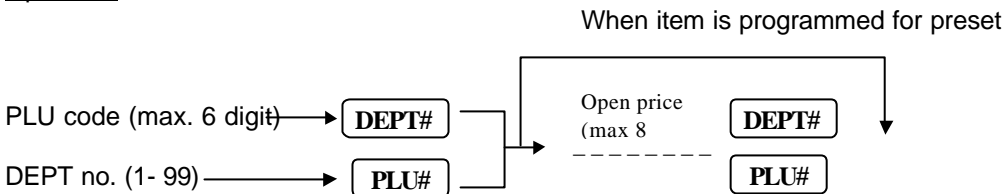

PLU entry by barcode scan⁴⁰

A PLU can be sold by scanning it's barcode.

Example (for above operations)

1000 **DEPT1**

DEPT2

Bar code scan

17 **PLU#** *

230 **OPEN
PRICE**

CASH

DATE	01/01/1996	MON
DEPT .1		■10.00
DEPT .2		■2.00
PIE		■1.00
PLU17		■2.30
TOTAL		■15.30
CASH		■15.30
CLERK1		#08
TIME 10:57		NO.000163

* In this example PLU# 17 is an open PLU.

REPEAT ENTRIES

Repeat

You can use this function when you sell two or more same items by pressing the same key.

Example

500 **PLU7**
PLU7
 15 **DEPT#**
DEPT#
DEPT3
DEPT3
CASH

DATE	01/01/1996	MON
PLU7		■5.00
PLU7		■5.00
DEPT.15		■2.00
DEPT.15		■2.00
DEPT.3		■3.50
DEPT.3		■3.50
TOTAL		■21.00
CLERK1		#08
TIME 12:32		NO.000375

Multiplication entries

You can use this function when you sell two or more same items, especially for a large quantity of items.

Operation

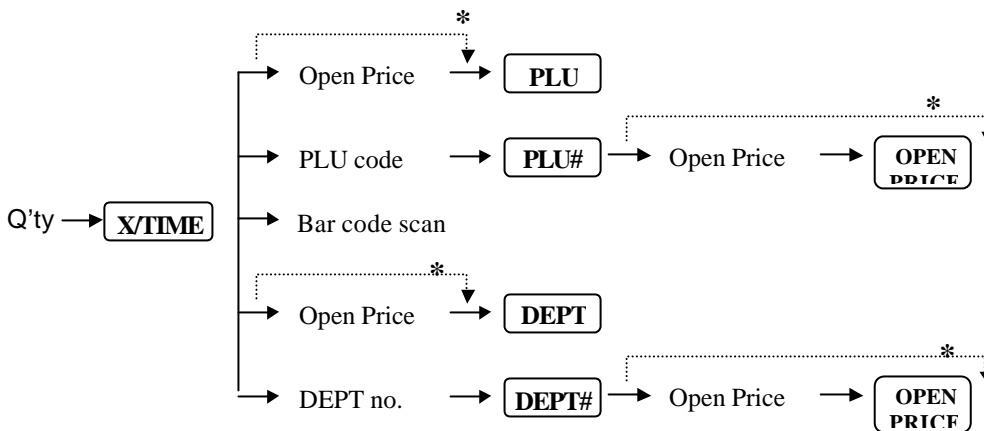

* When item is programmed for preset.

Example

3 **5** **X/TIME** **PLU3**
 12 **X/TIME**
 4 **PLU#** *
 250 **OPEN PRICE**
CASH

DATE	02/01/1996	TUE
3.50X		@3.00
PLU3		■10.50
12X		@2.50
PLU4		■30.00
TOTAL		■40.50
CASH		■40.50
CLERK1		#08
TIME 09:12		NO.000979

* In this example PLU# 4 is an open PLU.

SPLIT PRICING ENTRIES

You can use this function when a customer wants to purchase more or less than the base quantity.

Operation

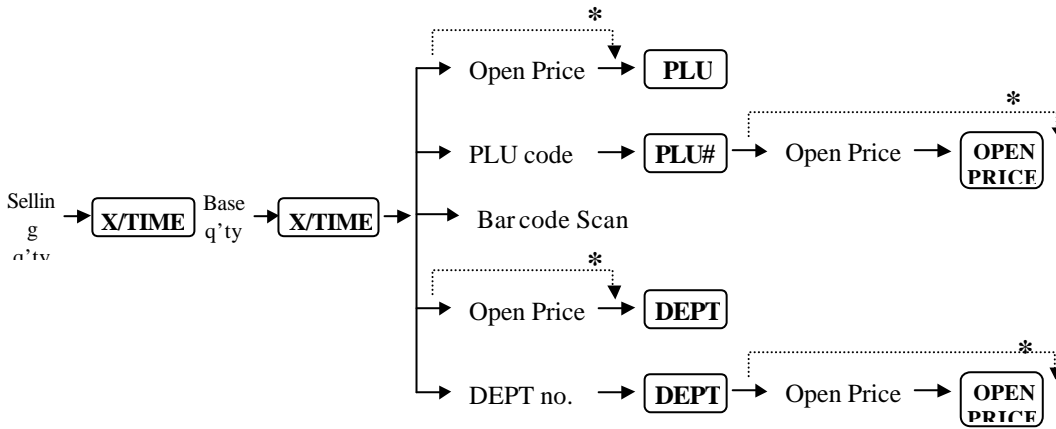

* When item is programmed for preset.

Example

3 **X/TIME**
 4 **X/TIME**
 8 **PLU#** *
 280 **OPEN PRICE**
CASH

DATE	02/01/1995	WED
3/4FOR		@2.80
PLU8		■2.10
TOTAL		■2.10
CASH		■2.10
CLERK1		#08
TIME	09:37	NO.001067

* In this example PLU# 8 is an open PLU.

FINALIZING OF TRANSACTION.

Key lock position : REG mode

Press the **SBTL** key at any point of transaction when you want to know the sale subtotal including tax. Then the sale subtotal will appear in the display.

Cash or cheque tendering

Enter the amount tendered by the customer and press the **CASH** key if it is a cash tender or press the **CHEQUE** key if it is a cheque tender. When the tendered amount is greater than the sale amount, the register will show the change due amount. Otherwise it will show a deficit and the message "SUBTOTAL".

Example

~
SBTL
2000 **CASH**

Charge tendering

Enter the amount tendered by the customer and press the **CHARGE** key or press charge# and **CHARGE#** key. The charge tendered amount can not exceed the sale amount.

If the amount is equal to the sale amount, it will finalize transaction ,or it will show a deficit and the message "SUBTOTAL".

Tendering without tender amount entry.

According to the sale type press the **CASH** key, **CHARGE** key, **CHARGE#** key, **CHEQUE** key or key without entering tender amount. Then the register will show the total sale amount.

Example

~
SBTL
CHARGE

DATE	04/01/1996	THU
PLU1		▪1.00
PLU1		▪1.00
PLU2		▪2.00
TOTAL		▪4.00
CHARGE2		▪4.00
CLERK1		#08
TIME	11:48	NO.011161

MIXED TENDERING.

Above three tendering method can be used together in one transaction.

Example

~

SBTL

10000 **CHEQU**

1

2000

CASH

DATE	04/01/1996	THU
PLU31		▪200.00
PLU21		▪30.00
TOTAL		▪230.00
CHEQUE		▪100.00
TOTAL		▪130.00
CHARGE1		▪20.00
TOTAL		▪110.00
CASH		▪110.00
CLERK1		#08
TIME	13:31	NO.012163

TAX OPERATION.

Key lock position : REG mode

Each PLU and DEPT can be programmed for tax1 through tax4. And there are four tax systems available. These are straight % VAT, Add on by tax table, Add on by straight% and GST(Canadian Goods & Services Tax). GST can be programmed only for tax4. Refer to the tax PGM part for detail.

Collecting tax.

Normal operation.

In normal transaction taxes are automatically collected according to the item's programmed tax status.

Example

1000

1000

1000

1000

DATE	04/01/1996	THU
PLU1 T1		▪10.00
PLU2 T2		▪10.00
PLU3 T3		▪10.00
PLU4		▪10.00
TAX AMT 1		▪0.50
TAX AMT 2		▪1.00
TAX AMT 3		▪1.50
TOTAL		▪43.00
CASH		▪43.00
CLERK1		#08
TIME	17:20	NO 012916

In the above example PLU1 is programmed for tax1, PLU2 is for tax2 and PLU3 is for tax3. And tax1, tax2 and tax3 are programmed for straight% add on tax. Tax1 rate is 5.00%, tax2 is 10.00% and tax3 is 15.00%.

Imposing tax using tax shift key.

When you need to impose a tax on an item which is not programmed for that tax, use tax shift function. Press tax no. and key before sell the item. This function affects the next one item entry, and can't impose tax on the sale subtotal.

Example

1000

1000

2

1000

2

1000

DATE	04/01/1996	THU
PLU1 T1		▪10.00
PLU2		▪10.00
PLU1 T12		▪10.00
PLU2 T2		▪10.00
TAX AMT 1		▪1.00
TAX AMT 2		▪2.00
TOTAL		▪43.00
CASH		▪43.00
CLERK1		#08
TIME	18:10	NO 012916

In the above example PLU1 is programmed for tax1. And tax1 and tax2 are programmed for straight % add on tax. Tax1 rate is 5.00% and tax2 is 10.00%.

EXEMPTING TAX.

Operation of tax exempt.

Several keys, including key, key, etc. can exempt taxes if it is programmed to do so. Refer to the key status PGM part for detail.

Example

1000

1000

1000

1000

DATE	04/01/1996	THU
PLU1 T1		▪10.00
PLU2 T2		▪10.00
PLU3 T3		▪10.00
PLU4 T4		▪10.00
TAX AMT 3		▪1.50
TAX AMT 4		▪2.00
TOTAL		▪43.50
CASH		▪43.50
CLERK1		#08
TIME 18:21		NO 013105

In the above example PLU1 is programmed for tax1, PLU2 is for tax2, PLU3 is for tax3 and PLU4 is for tax4. And tax1, tax2, tax3 and tax4 are programmed for straight% add on tax.

Tax1 rate is 5.00%, tax2 is 10.00%, tax3 is 15.00% and tax4 is 20.00%.

key is programmed to exempt tax1 and key is to exempt tax2.

Operation of tax exempt using tax key.

If the key is used after pressing key, it act as not a tax shift but a tax exempt.

Example

1000

1000

1000

1000

3

4

DATE	04/01/1996	THU
PLU1 T1		▪10.00
PLU2 T2		▪10.00
PLU3 T3		▪10.00
PLU4 T4		▪10.00
TAX AMT 1		▪0.50
TAX AMT 2		▪1.00
TOTAL		▪41.50
CASH		▪41.50
CLERK1		#08
TIME 18:29		NO 013210

In the above example PLU1 is programmed for tax1, PLU2 is for tax2, PLU3 is for tax3 and PLU4 is for tax4. And tax1, tax2, tax3 and tax4 are programmed for straight% add on tax.

Tax1 rate is 5.00%, tax2 is 10.00%, tax3 is 15.00% and tax4 is 20.00%.

R/A AND P/O FUNCTION

Key lock position : REG mode

If you want to prepare the change due in drawer before starting sale and enter the amount of the cash, use R/A and P/O function. For more detail about the R/A and P/O function will be discussed later.

R/A

Operation

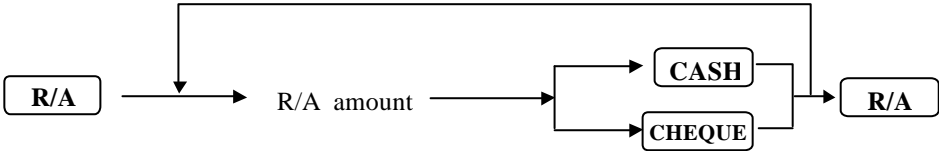

P/O

Operation

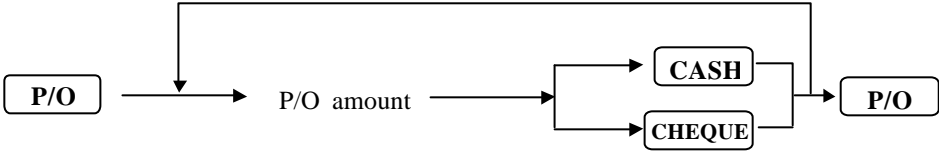

PRICE CHANGE

Use this function when a clerk needs to change the item's unit price. This function affects only the next one item entry. To use this function the item's price change enable flag in the status field must be set to 2.

Operation

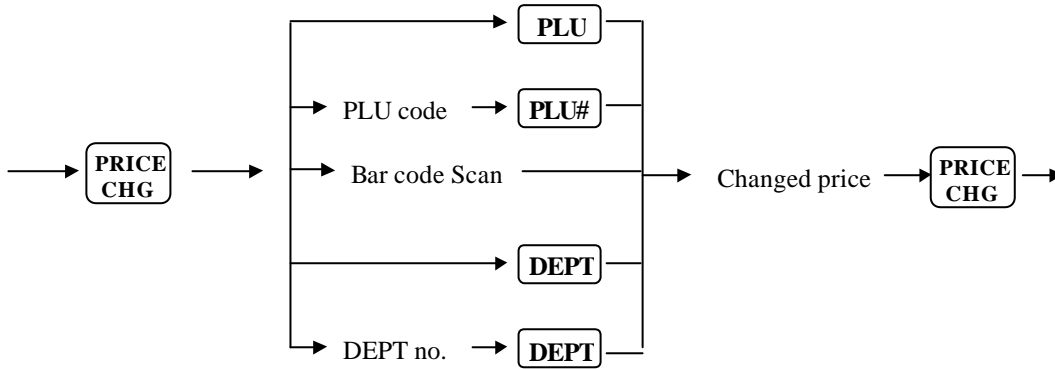

Example

PLU7
 PRICE CHG
 PLU7
 150 PRICE CHG
 PLU8
 PLU7
 CASH

DATE	02/01/1996	TUE
PLU7		■5.00
PLU7		■1.50
PLU8		■2.00
PLU7		■5.00
TOTAL		■13.50
CASH		■13.50
CLERK1		#08
TIME 10:01		NO.001121

NOT FOUND PLU

Not found PLU function automatically runs when you try to sell a PLU that is not exist.

Register will register that PLU and sell the item.

When function activated register will show "NOT FOUND" and turn on the buzzer.

If you want to ignore that PLU entry press key, or press key to continue.

To abort Not found PLU function during its operation, press key.

Operation

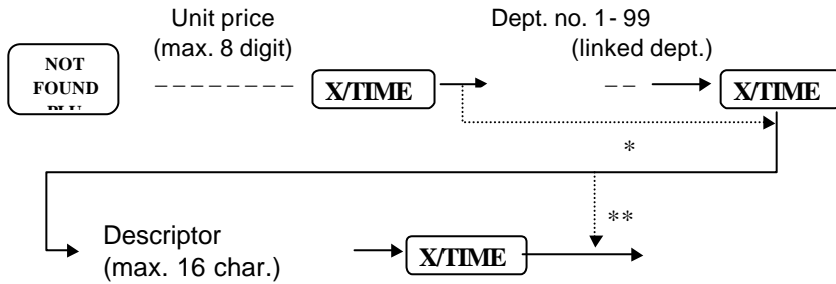

* When P mode program option 22B is set. (dept link is not compulsory. In this case if pressing without dept no. will link nothing.)

** When P mode program option 22C is set. (description entry skip)

Refer to the P mode program option programming for the details.

Example

```

    PLU2
123456 PLU#
    NOT FOUND
    PLU
    100 X/TIME *
    2 X/TIME **
    PIE X/TIME ***
    CASH
  
```

DATE	02/01/1996	TUE
PLU2		■2.00
PIE		■1.00
TOTAL		■3.00
CASH		■3.00
CLERK1		#08
TIME	10:09	NO.001129

* Price
 ** Linked dept
 *** Descriptor

PRICE ENQUIRY

When you need to know PLU's unit price during operation, use this function.
It will show both PLU's descriptor and unit price.

Operation

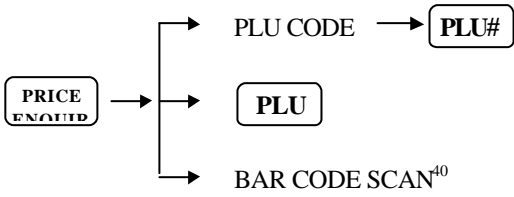

Other entries for PLU & DEPT.

Key lock position : REG mode

PRICE SHIFT

Two different price levels for PLUs and DEPT.s are available. Pressing second price key will change the price level from one to another. There are three different price level shift modes. (Refer to the S mode program option #17.)

Item popup mode

The item popup mode automatically shift the price level back to level 1 after one item sale.

Example

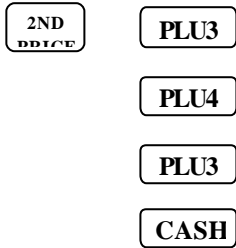

DATE	02/01/1996	TUE
PLU3		▪3.50
PLU4		▪4.00
PLU3		▪3.00
TOTAL		▪10.50
CASH		▪10.50
CLERK1		#08
TIME 12:31		NO.001321

Ticket popup mode

This mode automatically shift the price level back to level 1 after finalizing one transaction.

Example

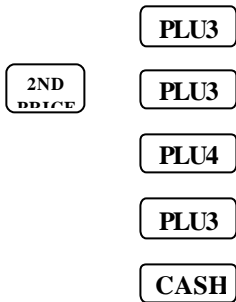

DATE	02/01/1996	TUE
PLU3		▪3.00
PLU3		▪3.50
PLU4		▪4.00
PLU3		▪3.50
TOTAL		▪14.00
CASH		▪14.00
CLERK1		#08
TIME 12:47		NO.001339

Stay down mode

This mode maintain price level until the next price level change.

LEVEL SHIFT (ONLY FOR DIRECT PLU)

You can use one direct PLU key in three levels with the level shift keys, LEVEL1 through LEVEL3. For example assume that each level contains 100 PLUs then LEVEL1 is for PLU1 through PLU100, LEVEL2 is for PLU101 through PLU200 and LEVEL3 is for PLU201 through PLU300. i.e. You can use 300 PLUs with 100 direct PLUs. There are three different level shift modes.

Item popup mode

The item popup mode automatically shift the PLU level back to level 1 after one item sale.

Example

MENU LEVEL2	PLU5	Sells PLU 125	<table style="width: 100%; border-collapse: collapse;"> <tr><td>DATE</td><td>02/01/1996</td><td>TUE</td></tr> <tr><td>PLU125</td><td></td><td style="text-align: right;">■4.00</td></tr> <tr><td>PLU5</td><td></td><td style="text-align: right;">■5.00</td></tr> <tr><td>TOTAL</td><td></td><td style="text-align: right;">■9.00</td></tr> <tr><td>CASH</td><td></td><td style="text-align: right;">■9.00</td></tr> <tr><td>CLERK1</td><td></td><td style="text-align: right;">#08</td></tr> <tr><td>TIME 14:22</td><td></td><td style="text-align: right;">NO 001499</td></tr> </table>	DATE	02/01/1996	TUE	PLU125		■4.00	PLU5		■5.00	TOTAL		■9.00	CASH		■9.00	CLERK1		#08	TIME 14:22		NO 001499
DATE	02/01/1996	TUE																						
PLU125		■4.00																						
PLU5		■5.00																						
TOTAL		■9.00																						
CASH		■9.00																						
CLERK1		#08																						
TIME 14:22		NO 001499																						
	PLU5	Sells PLU5																						
	CASH																							

Ticket popup mode

This mode automatically shift the PLU level back to level 1 after finalizing one transaction.

Example

	PLU5	Sells PLU 5	<table style="width: 100%; border-collapse: collapse;"> <tr><td>DATE</td><td>02/01/1996</td><td>TUE</td></tr> <tr><td>PLU5</td><td></td><td style="text-align: right;">■5.00</td></tr> <tr><td>PLU125</td><td></td><td style="text-align: right;">■4.00</td></tr> <tr><td>PLU125</td><td></td><td style="text-align: right;">■4.00</td></tr> <tr><td>TOTAL</td><td></td><td style="text-align: right;">■13.00</td></tr> <tr><td>CASH</td><td></td><td style="text-align: right;">■13.00</td></tr> <tr><td>CLERK1</td><td></td><td style="text-align: right;">#08</td></tr> <tr><td>TIME 14:35</td><td></td><td style="text-align: right;">NO.001513</td></tr> </table>	DATE	02/01/1996	TUE	PLU5		■5.00	PLU125		■4.00	PLU125		■4.00	TOTAL		■13.00	CASH		■13.00	CLERK1		#08	TIME 14:35		NO.001513
DATE	02/01/1996	TUE																									
PLU5		■5.00																									
PLU125		■4.00																									
PLU125		■4.00																									
TOTAL		■13.00																									
CASH		■13.00																									
CLERK1		#08																									
TIME 14:35		NO.001513																									
MENU LEVEL2	PLU5	Sells PLU 125																									
	PLU5	Sells PLU 125																									
	CASH																										

Stay down mode

This mode maintain level until the next PLU level change.

LINK PLU ENTRIES

Operation is the same as for normal PLU's. If a link PLU is sold then the linked PLU is sold too.

Example

PLU1
 PLU2 *
 CASH

DATE	02/01/1996	TUE
PLU1		▪1.00
PLU2		▪2.00
PLU3		▪3.00
TOTAL		▪6.00
CASH		▪6.00
CLERK1		#08
TIME	17:52	NO.002029

* In this example PLU3 is linked to PLU2.

Set menu entries

Operation is the same as for normal PLU's.

When you sell by pressing SETMENU# key then set menu's descriptor and preset price is printed.
 (Also the linked PLUs' descriptor will be printed if the P-Mode Printing Option #29 is set.)

Example

PLU1
 SET MENU 1 *
 CASH

DATE	02/01/1996	TUE
PLU1		▪1.00
SPECIAL		▪17.00
PLU2		
PLU3		
PLU4		
PLU5		
PLU6		
TOTAL		▪18.00
CASH		▪18.00
CLERK1		#08
TIME	10:24	NO.002700

* In this example PLU2 - PLU6 are linked to SET MENU1.

MIX AND MATCH OPERATION.

Each PLU can be linked to a mix and match table. You sell various items and when the mix and match table's item count reached the trip level, the sales amount is automatically discounted.

Example

PLU1
PLU1
PLU2
PLU2
PLU3
PLU2
PLU2
CASH

DATE	04/01/1996	THU
PLU1		▪1.00
PLU1		▪1.00
PLU2		▪2.00
PLU2		▪2.00
PLU3		▪3.00
PLU2		▪2.00
CHEAP!!!		-0.10
PLU2		▪2.00
TOTAL		▪12.90
CASH		▪12.90
CLERK1		#08
TIME	11:02	NO. 010780

In this example mix and match table #1 descriptor is "CHEAP!!!", discount amount is 0.1£ and trip level is 5. PLU1 and PLU2 are linked to mix and match table #1, and PLU3 is not linked to any mix and match table.

CORRECTIONS

Key lock position : REG mode

Error correct

If you made any incorrect item, percentage, deduction or refund entry by mistake you can void this by pressing

ERROR key immediately after the incorrect one.

CORRECT

Example

PLU1

PLU1

ERROR
CORRECT

PLU2

CASH

DATE	04/01/1996	THU
PLU1		■1.00
PLU1		■1.00
ERR CORRECT	-----	
PLU1		-1.00
PLU2		■2.00
TOTAL		■3.00
CASH		■3.00
CLERK1		#08
TIME	10:20	NO 012261

Previous void with VOID key.

When you made any incorrect item, percentage, deduction or refund entry during the transaction , you can void this by specifying incorrect entries before finalizing the transaction.

Example

PLU1

200 **PLU2**

DEPT3

DEPT4

VOID

200 **PLU2**

VOID

DEPT3

CASH

DATE	05/01/1996	FRI
PLU1		■1.00
PLU2		■2.00
DEPT.3		■3.50
DEPT.4		■4.20
VOID	-----	
PLU2		-2.00
VOID	-----	
DEPT.3		-3.50
TOTAL		■5.20
CASH		■5.20
CLERK1		#08

Refund function

Key lock position : VOID mode

Refund operation has the same function which available in normal sale except for the key lock position. When refund operation needed, turn the mode switch to the VOID mode and do refund operation.

ALL VOID

You can void an entire transaction by pressing **CANCEL** key before finalizing it.
When you press **CANCE** key, the transaction will be aborted.

Example

300 **PLU4**
DEPT2
PLU2
CANCE

DATE	05/01/1996	FRI
PLU4		■10.00
DEPT.2		■3.00
CANCEL	-----	
CLERK1		#08
TIME 09:17		NO.020012

Promo & Waste

Key lock position : REG mode

Promo

When you need to offer an item to the customer with no charge, use this function.
Press **PROM** key before making an item entry which will be offered.

Example

PLU1
PROMO
PLU1
PLU20
CASH

DATE	05/01/1996	FRI
PLU1		■1.00
***** PROMO *****		
PLU1		-1.00
PLU20		■2.10
TOTAL		■2.10
CASH		■2.10
CLERK1		#08
TIME 12:22		NO.021074

WASTE

When you need to discard items use this function.

Press **WASTE** key before making an item entry and then enter items.

Press **WASTE** key again when you finish entering item entries which will be discarded.

Example

300 **WASTE**
PLU1
PLU2
DEPT17
WASTE

DATE	05/01/1996	FRI
***** WASTE *****		
PLU1		■3.00
PLU2		■2.00
DEPT.17		■2.30
***** WASTE *****		
TOTAL		■7.30
CLERK1		#08
TIME	19:42	NO.022125

Other entries

Key lock position : REG mode

PERCENT OPERATION

% entry

According to the programmed status, % key can be used as a % entry or an amount entry

According to the % key's programmed status, it will act as a premium key or a discount key.

And it can be programmed for item entries or for the subtotal.

- For item entries

Operation

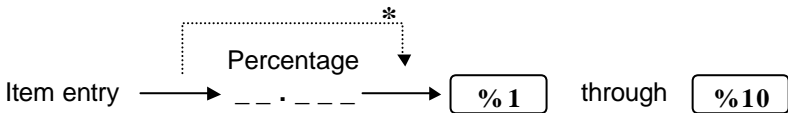

* When % key is programmed for preset.

Example

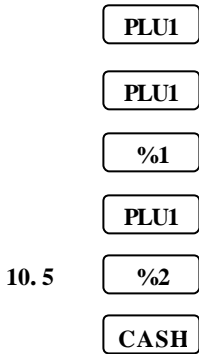

DATE	08/01/1996	MON
PLU1		■1.00
PLU1		■1.00
% 1		-12.000%
AMOUNT		-0.12
PLU1		■1.00
% 2		-10.500%
AMOUNT		-0.11
TOTAL		■2.77
CASH		■2.77
CLERK1		#08
TIME	09:25	NO 02388

- For the subtotal

Operation

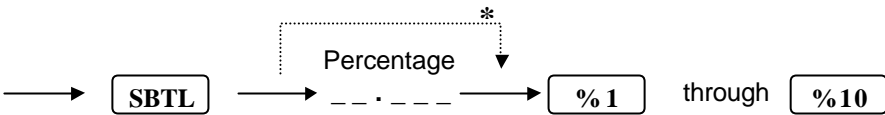

* When % key is programmed for preset.

Example

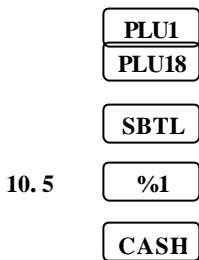

DATE	08/01/1996	MON
PLU1		■1.00
PLU2		■1.20
% 1		-10.500%
AMOUNT		-0.24
TOTAL		■1.96
CASH		■1.96
CLERK1		#08
TIME	09:51	NO 022481

DISCOUNT AMOUNT

When % key is used for amount operation, it act as a deduction entry.
And it can be programmed for item entries or for the subtotal.

- For item entries

Operation

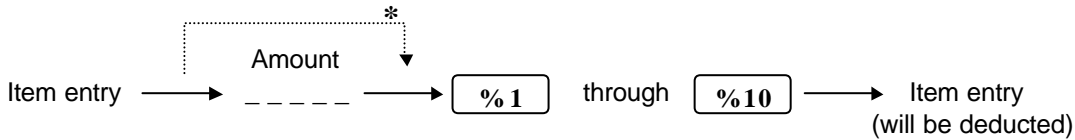

* When % key is programmed for preset.

Example

200

PLU1

PLU8

% 1

PLU1

CASH

DATE	08/01/1996	MON
PLU1		▪1.00
PLU8		▪8.00
PLU1 -C		-2.00
AMOUNT		-0.24
TOTAL		▪7.00
CASH		▪7.00
CLERK1		#08
TIME 10:01		NO.023487

- For the subtotal

Operation

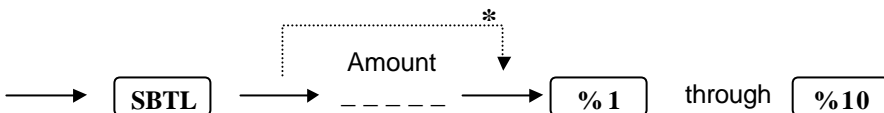

* When % key is programmed for preset.

Example

120

PLU2

DEPT8

SBTL

% 1

CASH

DATE	08/01/1996	MON
PLU2		▪2.00
DEPT.8		▪8.10
% 1		-1.20
TOTAL		▪8.90
CASH		▪8.90
CLERK1		#08
TIME 10:17		NO.023533

NON ADD # ENTRY

When you need to print specific code on the receipt such as a credit card number then enter a non-add number and press **# / NS** key at any time during the transaction or before starting the transaction.

Example

PLU1
122 **PLU#**
79 **DEPT#**
22735 **# / NS**
CASH

DATE	08/01/1996	MON
PLU1		▪1.00
PLU122		▪5.10
DEPT.79		▪2.30
NON-ADD NO.		#22735
TOTAL		▪8.40
CASH		▪8.40
CLERK1		#08
TIME 11:30		NO.023600

No sale

Press **# / NS** without any entry. The drawer will open and you can exchange.

CURRENCY EXCHANGE

The register has 2 kind of foreign currency exchange.

To use this function you must program the foreign currency exchange rate of the currency key.

Operation

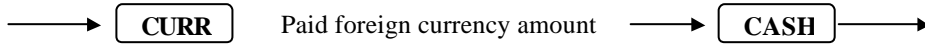

Example

100 **PLU1**
 200 **PLU2**
 CURR1 *
 400 **CASH**
 CASH

DATE	08/01/1996	MON
PLU1		■1.00
PLU2		■2.00
TOTAL		■3.00
CHANGE RATE		#2
CURR CONV 1		@6.00
FOREIGN AMT		4.00
HOME AMT		■2.00
TOTAL		■1.00
CASH		■1.00
CLERK1		#08
TIME	15:20	NO 024000

* In this example currency exchange rate for **CURR1** key is 2.0

CHECK OPERATION

Key lock position : REG mode

Two different check entry systems are available. One is Soft check system and the other is Hard check system. It depends on the check type on the all clear procedure.

Soft check : In this mode, the balance due and the details of the order are stored in the check memory. Check contents will be printed while you finish the transaction with payment. Or you can print the bill using the **PRT CHK** key.

Hard check : In this mode, only the previous balance is stored in the check memory. The bill contents will be printed whenever you make the check serve operation so you can have the whole bill after payment.

The **PRT CHK** key do nothing in this mode.

New check

For a new guest, open a new check and assign a check number. And then finalizing the transaction temporarily using **SERVICE TOTAL** key.

Additional ordering

For an existing guest, enter the check number and press **CHECK#** key. The previous balance will be displayed.

Make a sale and end the transaction temporary using **SERVICE** key or finish the transaction completely by the payment (See the previous section).

Bill Printing

Print Check

In the soft check mode use **PRT CHK** key while the check is opened, or enter the check number and press **PRT CHK** key. The printing port is defined in the **PRT CHK** key status in the soft check mode. The full details of the check will be printed everytime

Slip Print

In the soft check mode the **Slip Print** key prints only details that have not already been printed. Insert the Bill into the slip printer. Enter the check number and press the **Slip Print** key, the slip printer will print any details that have not already been printed. The next time you want to print details on this check reinsert the SAME bill, enter the check number and press the **Slip Print** key. The printer will feed one line below the previous details and print any details that has not already been printed.

Hard Check Printing

In the hard check mode use bill contents are printed whenever you end the transaction temporary using

SERVICE TOTAL key. The printing port is defined in the **SERVICE TOTAL** key status in the hard check mode.

BILL ADDITION

Follow the following procedure to add some bills.
All bills are added to the first bill.

	ADD CHECK
1	CHECK #
2	CHECK #
3	CHECK #
	SERVICE TOTAL

```

DATE    09/01/1996    TUE
      ** ADD CHECK **
CHECK#           #1
P/BAL           ■1.00
CHECK#           #2
P/BAL           ■2.00
CHECK#           #3
P/BAL           ■3.00

CLERK1           #08
TIME 12:50      NO.025076
    
```

* You can finish the transaction by the payment procedure instead of the

SERVICE TOTAL

 key.

Bill transfer

Follow the following procedure to change the check number.

1	TRANS CHECK
2	TRANS CHECK

```

DATE    09/01/1996    TUE
      ** TRANS CHECK **
CHECK#           #1
P/BAL           ■6.00
CHECK#           #2
P/BAL           ■6.00

CLERK1           #08
TIME 13:27      NO.025155
    
```

Check #1 is transferred to the Check #2.

CLERK INTERRUPT OPERATION.

Key lock position : REG mode

This function will not work if P mode communication option #6 is not programmed.
Both push button clerk entry and clerk code entry can be used together.

This function makes you change from one clerk to another in the middle of transaction.
If clerk interrupted during the transaction the register will temporarily tender the current transaction and the first clerk is signed off, then the second clerk signs on automatically.
If the second clerk has previously temporarily tendered transaction, register will recall the amount.
Clerk registration for clerk interrupt is different from the normal registration.
See below for detail.

Clerk registration for clerk interrupt operation.

Clerk code entry with clerk no.

--

Clerk no. which will be displayed.

CASHIER

CLERK SIGN OFF FOR CLERK INTERRUPT OPERATION.

To sign off directly in the middle of transaction, simply press **CASHIER** key.
Then the register will temporarily tender the current transaction, and directly sign off .

Example

Clerk 1 registered and make transaction.

Clerk 1
Registration
~
PLU25
120 **PLU17**

DATE	09/01/1996	TUE
PLU25		▪2.00
PLU17		▪1.40
SERVICE		▪3.40
BFWD		▪3.40
CLERK1		#01
CLERK3		#08
TIME 14:20		NO.025237

Clerk1 is interrupted and clerk3 registered.

Clerk 3*
Registration (for clerk interrupt)
~
1100 **PLU25**
PLU19
CASH

DATE	09/01/1996	TUE
PLU25		▪11.00
PLU19		▪2.51
TOTAL		▪13.51
CASH		▪13.51
CLERK3		#08
TIME 14:32		NO.025238

Clerk1 register again and go on.

Clerk 1**
Registration (for clerk interrupt)
~
PLU38
DEPT2
SBTL ***
CASH

DATE	09/01/1996	TUE
P/BAL		▪3.40
PLU38		▪0.50
DEPT.2		▪2.30
TOTAL		▪6.20
CASH		▪6.20
CLERK1		#08
TIME 14:47		NO.025261

- * Register temporarily close transaction when the clerk is interrupted by another clerk.
- ** Register recalls previous sale amount if the newly registered clerk has a temporarily closed transaction.
- *** Pressing **SBTL** key can be programmed as compulsory when finalizing transaction in clerk interrupt operation

Clerk Interrupt can also be programmed for floating clerk system. This allows a clerk detail and sales value to be transferred from one register to another. Therefore a clerk can start off a transaction on one register and finalize it on another.

TRAINING MODE

Training mode is used when the clerk practices various register operations.
Operations under training mode does not affect memories except for training total memory.
Register will update only the training total area memory if it is in training mode.
This function will not work if P mode program option #18 is not programmed.

Enter training mode

Key lock position : X mode

Operation

88

SBTL

xxxx

X/TIME

Enter training password

CASH

Exit training mode

Key lock position : X mode

Operation

88

SBTL

0000

X/TIME

CASH

RECEIPT ISSUE

Key lock position : REG mode

Receipt on/off operation

If you press the  key, it will toggle receipt on/off status and turn on/off the "RCPT OFF" lamp. If register is in RCPT OFF status it will not issue a receipt.

Post receipt operation.

* This function will not work if P mode printing option #13A is not set.

If you need one more copy of receipt press the  key.

And you can select either a copy receipt is printing full item or printing total amount only.

(For details, refer to the P mode printing option #14B)

REPORTS

Key lock position : X mode or Z mode

Cash declaration

If you want to verify the amount in the drawer when issuing financial report, use cash declaration function. Then the register will compare the amount in memory with the declared amount and print the difference in financial report.

Operation

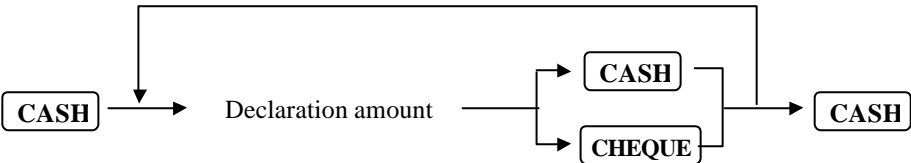

Example

CASH
52400 **CASH**
20000 **CHEQU**
CASH

DATE	09/01/1996	TUE
*** CASH DECLARATION ***		
CASH		524.00
CHEQUE		200.00
TOTAL		724.00
CLERK1		#08
TIME	19:07	NO.026145

REPORT LIST

Reports.

Turn mode key to X (read) or Z (reset) Position

Use this function, to consolidate all the sales information for a number of registers.

Operation

Report Code

SBTL

CASH

Consolidating Reports.

Turn mode key to X (read) or Z (Reset) Position

Use this function, to consolidate all the sales information for a number of registers.

Operation

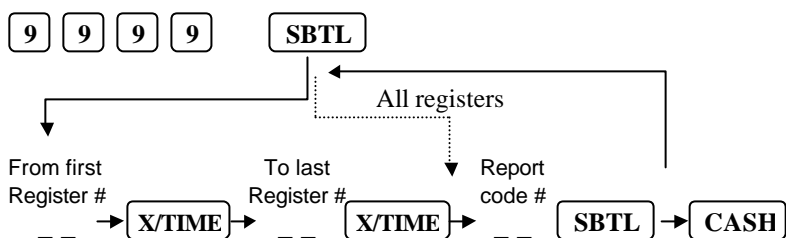

Consolidating Reports.

Turn mode key to X (read) or Z (reset) Position

Use this function, to consolidate all the sales information for a number of registers.

Operation

Report Code

SBTL

CASH

REPORT LIST

REPORT	NO.	REPORT MODE	KEY LOCK POSITION	KEY SEQUENCE	IRC
FINANCIAL	1	X	X	1 SUBTOTAL	YES
		Z	Z	1 SUBTOTAL	
		X2	X	21 SUBTOTAL	
		Z2	Z	21 SUBTOTAL	
		X3 ⁰⁰	X	31 SUBTOTAL	
		Z3 ⁰⁰	Z	31 SUBTOTAL	
SALES TIME	2	X	X	2 SUBTOTAL	YES
		Z	Z	2 SUBTOTAL	
		X2	X	22 SUBTOTAL	
		Z2	Z	22 SUBTOTAL	
		X3 ⁰⁰	X	32 SUBTOTAL	
		Z3 ⁰⁰	Z	32 SUBTOTAL	
ALL PLUs	3	X	X	3 SUBTOTAL	YES
		Z	Z	3 SUBTOTAL	
		X2	X	23 SUBTOTAL	
		Z2	Z	23 SUBTOTAL	
		X3 ⁰⁰	X	33 SUBTOTAL	
		Z3 ⁰⁰	Z	33 SUBTOTAL	
FROM/TO PLUs *	4	X	X	4 SUBTOTAL	YES
		Z	Z	4 SUBTOTAL	
		X2	X	24 SUBTOTAL	
		Z2	Z	24 SUBTOTAL	
		X3 ⁰⁰	X	34 SUBTOTAL	
		Z3 ⁰⁰	Z	34 SUBTOTAL	
ALL CLERKs	5	X	X	5 SUBTOTAL	YES
		Z	Z	5 SUBTOTAL	
		X2	X	25 SUBTOTAL	
		Z2	Z	25 SUBTOTAL	
		X3 ⁰⁰	X	35 SUBTOTAL	
		Z3 ⁰⁰	Z	35 SUBTOTAL	
INDIVIDUAL CLERK **	6	X	X	6 SUBTOTAL	YES
		Z	Z	6 SUBTOTAL	
		X2	X	26 SUBTOTAL	
		Z2	Z	26 SUBTOTAL	
		X3 ⁰⁰	X	36 SUBTOTAL	
		Z3 ⁰⁰	Z	36 SUBTOTAL	

* FROM/TO PLUs report operation .

4 - - Start PLU# - - End PLU# -

** INDIVIDUAL CLERK report operation.

6 - - Clerk# -

REPORT LIST

REPORT	NO.	REPORT MODE	KEY LOCK POSITION	KEY SEQUENCE	IRC
CASH IN DRAWER	7	X X2 X3 ⁰⁰	X X X	7 SUBTOTAL 27 SUBTOTAL 37 SUBTOTAL	YES
CHEQUE IN DRAWER	8	X X2 X3 ⁰⁰	X X X	8 SUBTOTAL 28 SUBTOTAL 38 SUBTOTAL	YES
NORMAL GROUPs	9	X Z X2 Z2 X3 ⁰⁰ Z3 ⁰⁰	X Z X Z X Z	9 SUBTOTAL 9 SUBTOTAL 29 SUBTOTAL 29 SUBTOTAL 39 SUBTOTAL 39 SUBTOTAL	YES
LABOUR GROUPs	10	X Z X2 Z2 X3 ⁰⁰ Z3 ⁰⁰	X Z X Z X Z	10 SUBTOTAL 10 SUBTOTAL 210 SUBTOTAL 210 SUBTOTAL 310 SUBTOTAL 310 SUBTOTAL	NO
DAILY SALES	11	X2 Z2 X3 ⁰⁰ Z3 ⁰⁰	X Z X Z	211 SUBTOTAL 211 SUBTOTAL 311 SUBTOTAL 311 SUBTOTAL	NO
ALL CLERKS TIME REPORT	12	X Z X2 Z2 X3 ⁰⁰ Z3 ⁰⁰	X Z X Z X Z	12 SUBTOTAL 12 SUBTOTAL 212 SUBTOTAL 212 SUBTOTAL 312 SUBTOTAL 312 SUBTOTAL	NO
INDIVIDUAL CLERKS TIME REPORT	13	X Z X2 Z2 X3 ⁰⁰ Z3 ⁰⁰	X Z X Z X Z	13 SUBTOTAL 13 SUBTOTAL 213 SUBTOTAL 213 SUBTOTAL 313 SUBTOTAL 313 SUBTOTAL	NO
PLUs BY DEPT.	14	X X2 X3 ⁰⁰	X X X	14 SUBTOTAL 214 SUBTOTAL 314 SUBTOTAL	YES
PLUs BY INDIVIDUAL DEPT.	15	X X2 X3 ⁰⁰	X X X	15 SUBTOTAL 215 SUBTOTAL 315 SUBTOTAL	YES

REPORT LIST

REPORT	NO.	REPORT MODE	KEY LOCK POSITION	KEY SEQUENCE	IRC
DEPT.	16	X	X	16 SUBTOTAL	YES
		Z	Z	16 SUBTOTAL	
		X2	X	216 SUBTOTAL	
		Z2	Z	216 SUBTOTAL	
		X3 ⁰⁰	X	316 SUBTOTAL	
Z3 ⁰⁰	Z	316 SUBTOTAL			
ALL PLU CURRENT STOCK	17	X	X	9999 SUBTOTAL	YES
		Z	Z	17 SUBTOTAL	
NOT FOUND PLU	18	X	X	17 SUBTOTAL	NO
		Z	Z	17 SUBTOTAL	
MINIMUM STOCK	19	X	X	9999 SUBTOTAL	YES
		Z	Z	19 SUBTOTAL	
FROM/TO CURRENT STOCK *	20	X	X	9999 SUBTOTAL	YES
		Z	Z	20 SUBTOTAL	
M & M	40	X/Z	X/Z	9999 SUBTOTAL 40 SUBTOTAL	YES
STOCK BY INDIV DEPT.	41	X	X	41 SUBTOTAL	NO PERFORMS AUTO IRC.
ALL OPEN CHECKs	160	X	X	160 SUBTOTAL	NO*
		Z	Z	160 SUBTOTAL	
INDIVIDUAL OPEN CHECK	161	X	X	161 SUBTOTAL	NO*
		Z	Z	161 SUBTOTAL	
CHECKs FOR CLERK INT.	162	X	X	162 SUBTOTAL	NO*
		Z	Z	162 SUBTOTAL	
CHECKs OPENED BY CLERK	170	X	X	170 SUBTOTAL	NO*
		Z	Z	170 SUBTOTAL	
PRE-POLLED REPORT**	180	X	X	180 SUBTOTAL	NO
Z		Z	Z	180 SUBTOTAL	
STRING REPORT***	10X	X	X	10X SUBTOTAL	YES
		Z	Z	10X SUBTOTAL	
		X2	X	210X SUBTOTAL	
		Z2	Z	210X SUBTOTAL	
		X3 ⁰⁰	X	310X SUBTOTAL	
Z3 ⁰⁰	Z	310X SUBTOTAL			

REPORT LIST

** CHECK REPORTS

- All check reports (160 - 170) are effective when running on the master ECR (which holds the check tracking data. Refer to the P mode communication option #6 for detail.)
- You must program S mode program option #15B and clerk interrupt or opened check must be closed to run
 - Z - check report. Otherwise ECR will not generate any report.
- Individual opened check report operation.

161 - - Start check# - - End check# -

- Checks opened by clerk report operation.

170 - - Clerk# -

** PRE-POLL REPORT

- Prints pre-poll report.
- IRC reporting on register will not work when pre-polling done but not fetched by PC.
If you want not to get the pre-poll reports via PC but to clear them, run the pre-poll reporting function in Z-mode. Then the pre-poll reports are cleared and IRC reporting will work.

*** STRING REPORTS

- 5 string reports are available where X is the string report number.
- String reports can be programmed to run at a specific time (A scheduled time)

ERROR MESSAGES

ERROR MESSAGE DESCRIPTOR DEFINITIONS

1. BUFF. FULL - The buffer for check has reached capacity.
2. REQ AMOUNT - This operation requires an amount entry.
3. NO PLU! - The number entered is not a valid PLU.
4. HALO OVER - The amount entered exceeds the programmed HALO.
5. INACTIVE! - The key pressed is inactive or VOID mode is inactive.
6. F-STAT ERR - Function key status is wrong.
7. REQ GAL AMT - This entry involves a gallonage PLU, and requires an amount entry.
8. NEGATIVE - This sale has gone negative. Negative sale is not allowed.
9. REQ COND! - This item has been programmed to require a condiment entry.
10. NOT PGMMED! - This key has not been programmed.
11. OVERRIDE X - The keylock has to be moved to the X-Mode in order to override an HALO amount, or other restriction.
12. NO OVERRIDE - X-Mode override is not allowed.
13. NO MANUAL - Manual entry is not allowed (scale function).
14. SYS-OPN ERR - System option is wrong.
15. OPEN DRAWER - The register has been programmed not to operate with the cash drawer open.
16. NO LINK PLU - Number of linked PLU is over 20 or linked PLU is not found.
17. NO SINGLE! - This PLU has been programmed as a single item PLU and can not be used within a sale.
18. REQ NONADD# - This operation requires the entry of a Non-Add number.
19. ZERO AMT - The register has been programmed to not allow negative sales, and to consider a zero amount as a negative sale.
20. REQ ADDCHK - Not used currently.
21. REQ R/A! - The operator is in the middle of a received on account operation, which requires a final depression of the R/A key to finalize the operation.
22. REQ P/O! - The operator is in the middle of a paid out operation, which requires a final depression of the P/O key to finalize the operation.
23. REQ VALID - This operation requires validation.
24. REQ EAT-IN - This operation requires a depression of either EAT-IN, TAKE-OUT or DRIVE-THRU keys.
25. REQ SCL PLU - Not used currently.
26. REQ SCALE - This item requires an amount entry via SCALE key (either auto or manual)
27. K-PRN FAIL The kitchen printer has failed to respond.
28. SEQ.ERROR - The preceding key sequence is not allowed.
29. REQ TARE# - This PLU/scale item requires a tare weight entry.
30. CASH-I-OVER - The Programmed Cash-In-Drawer limit has been exceeded.
31. REQ SUB KEY - The SUBTOTAL key must be depressed before continuing.
32. CHECK# AUTO - The operator has attempted to open a new guest check by assigning a check number. The register has been programmed to generate its own check numbers.
33. REQ TABLE# - Table number entry is required to open a guest check.
34. REQ GUEST# - The operator must enter the number of guests when opening a guest check.
35. NOT DISCNT - The preceding entry is not discountable.

- 36. NO SAME CLK - The clerk attempting to open this guest check is not the original clerk who started the guest check.
- 37. NO DATA - The PLU can not be found. This message is displayed other than REG mode.
- 38. NO CHECK # - The check can not be found.
- 39. COMP XMODE! - This operation requires the keylock to be turned to the X position.
- 40. CHANGE BACK - Money has declared for received on account..
- 41. USING! - The check is being used.
- 42. OFF LINE! - IRC communication is off line.
- 43. NOT READY! - Remote printer is not ready.
- 44. NOW REAL! - Not used currently.
- 45. CLK INT ERR - An error has occurred while clerk interrupt.
- 46. SIGN OFF - Current operator has to sign off to sign on another operator if signon method is using clerk secrete code.
- 47. REQ DEPT LK - Department link is compulsory.
- 48. REQ GRP LK - Group link is compulsory.
- 49. HALO ERROR - The number length is differ that is defined in the NS key HALO.
- 50. TENDER AMT - Amount is complusory at tender.
- 51. SYSTEM ERR - Normal error.
- 52. RANGE OVER - The number entered is out of range.
- 53. E MODE - The keylock is in the wrong position.
- 54. OPERATION - The operator has used an illegal key sequence.
- 55. BAD VALUE - The number entered is wrong.
- 56. DUPLICATE - The check is already exist.
- 57. REQ SIGNON - Sign on required.
- 58. PAPER END - The guest check printer has reached the of the form.
- 59. MEMORY FULL - Memory is full.
- 60. BAD FUNC - Memory file number is wrong.
- 61. BUSY - Destination register is busy.
- 62. M&M ERR - An error has occurred while mix and match operation.
- 63. NOT ZERO - The PLU operator attempts to delete has sale count/amount.
- 64. NO DRAWER! - The drawer is no longer attached and is required in order to continue.
- 65. NO PAPER - Slip printer is out of paper.
- 66. REQ WASTE - The operator is in the middle of a waste operation, and must depress the WASTE key in order to complete the operation.
- 67. REQ P/BAL - The register has been programmed to operate as a pre-check machine, and requires a previous balance entry.
- 68. REQ CHECK# - This register has been programmed to allow manual check number entry to begin a guest check transaction.
- 69. REMOV PAPER - Validation is complete and the form must be removed.
- 70. REQ CA DEC - Cash declaration has been programmed as compulsory, and must first be performed before reports may be generated.
- 71. CRC ERROR - An error has occurred in block checksum.
- 72. ZERO PRICE - Zero price item sale is not allowed.
- 73. ERROR - General error message.

TRANSMISSION ERRORS

On the ECR in the event of a communications fail. The ECR prints a message which can give information as to why the communications have failed.

e.g.

TX Fail (1C) [9998 14:09]

The 1C is a parameter passed between on of the routines within the ECR. In some cases this number may be -42 in which case this means that the destination ECR is OFF LINE. The Number 9998 is an example of the error code which will be explained in the table below.

14:09 was the time at which this error occurred.

Error Number Codes :

Code Number	Explanation
2101	The ECR is In Z Lock
2102	The ECR is in Z Unlock
2107	The Command failed during a X Consolidation
2108	The Command failed during a Z Consolidation
2109	The ECR failed during an Inline Consolidation Of Grand totals
210A	IN_GRAND_COL1
2207	The ECR failed during and Inline X Consolidation
2208	The ECR failed during an Inline Z Consolidation
2308	The ECR failed during an Inline report Request
3107	The ECR failed to download Date & Time
3207	The ECR failed during Program data download
3307	The ECR failed during PLU maintenance
3407	The ECR failed during A Clerk Time I/O Operation
3507	The ECR failed during a CHECK management operation
3607	The ECR failed during the Finalisation of a CHECK
4A05	The ECR failed during a Z-Clear operation
5A05	The ECR failed to send information to a KP
6A05	The ECR failed to send information to a KV
FFFF	NO_RES_CMD
9998	The ECR failed an internal IRC test.
9999	IN_INLINE_LB

